

SUPER  [®]

X8DTN+
X8DTN+-LR

USER'S MANUAL

Revision 1.2

The information in this User's Manual has been carefully reviewed and is believed to be accurate. The vendor assumes no responsibility for any inaccuracies that may be contained in this document, makes no commitment to update or to keep current the information in this manual, or to notify any person or organization of the updates. **Please Note: For the most up-to-date version of this manual, please see our website at www.supermicro.com.**

Super Micro Computer, Inc. ("Supermicro") reserves the right to make changes to the product described in this manual at any time and without notice. This product, including software and documentation, is the property of Supermicro and/or its licensors, and is supplied only under a license. Any use or reproduction of this product is not allowed, except as expressly permitted by the terms of said license.

IN NO EVENT WILL SUPER MICRO COMPUTER, INC. BE LIABLE FOR DIRECT, INDIRECT, SPECIAL, INCIDENTAL, SPECULATIVE OR CONSEQUENTIAL DAMAGES ARISING FROM THE USE OR INABILITY TO USE THIS PRODUCT OR DOCUMENTATION, EVEN IF ADVISED OF THE POSSIBILITY OF SUCH DAMAGES. IN PARTICULAR, SUPER MICRO COMPUTER, INC. SHALL NOT HAVE LIABILITY FOR ANY HARDWARE, SOFTWARE, OR DATA STORED OR USED WITH THE PRODUCT, INCLUDING THE COSTS OF REPAIRING, REPLACING, INTEGRATING, INSTALLING OR RECOVERING SUCH HARDWARE, SOFTWARE, OR DATA.

Any disputes arising between manufacturer and customer shall be governed by the laws of Santa Clara County in the State of California, USA. The State of California, County of Santa Clara shall be the exclusive venue for the resolution of any such disputes. Supermicro's total liability for all claims will not exceed the price paid for the hardware product.

FCC Statement: This equipment has been tested and found to comply with the limits for a Class A digital device pursuant to Part 15 of the FCC Rules. These limits are designed to provide reasonable protection against harmful interference when the equipment is operated in a commercial environment. This equipment generates, uses, and can radiate radio frequency energy and, if not installed and used in accordance with the manufacturer's instruction manual, may cause harmful interference with radio communications. Operation of this equipment in a residential area is likely to cause harmful interference, in which case you will be required to correct the interference at your own expense.

California Best Management Practices Regulations for Perchlorate Materials: This Perchlorate warning applies only to products containing CR (Manganese Dioxide) Lithium coin cells. "Perchlorate Material-special handling may apply. See www.dtsc.ca.gov/hazardouswaste/perchlorate".

WARNING: Handling of lead solder materials used in this product may expose you to lead, a chemical known to the State of California to cause birth defects and other reproductive harm.

Manual Revision 1.2

Release Date: Jan. 27, 2012

Unless you request and receive written permission from Super Micro Computer, Inc., you may not copy any part of this document.

Information in this document is subject to change without notice. Other products and companies referred to herein are trademarks or registered trademarks of their respective companies or mark holders.

Copyright © 2012 by Super Micro Computer, Inc.
All rights reserved.

Printed in the United States of America

Preface

About This Manual

This manual is written for system integrators, PC technicians and knowledgeable PC users. It provides information for the installation and use of the **SUPER** X8DTN+/X8DTN+-LR motherboard.

About This Motherboard

The **SUPER** X8DTN+/X8DTN+-LR supports the Intel 5500/5600 Series Processors, the first dual-processing platform that offers Intel QuickPath Interconnect (QPI) Technology to provide the next generation point-to-point system interface, replacing the current Front Side Bus. With the 5500/5600 Series Processors built in, the X8DTN+/X8DTN+-LR substantially enhances system performance with increased bandwidth and unprecedented scalability. This motherboard is optimized for intensive-applications and high-end servers. Please refer to our web site (<http://www.supermicro.com/products/>) for processor and memory support updates. This product is intended to be installed and serviced by a professional technician.

Manual Organization

Chapter 1 describes the features, specifications and performance of the motherboard and provides detailed information about the 5520 chipset.

Chapter 2 provides hardware installation instructions. Read this chapter when installing the processor, memory modules and other hardware components into the system. If you encounter any problems, see **Chapter 3**, which describes troubleshooting procedures for video, memory and system setup stored in the CMOS.

Chapter 4 includes an introduction to the BIOS and provides detailed information on running the CMOS Setup utility.

Appendix A lists BIOS POST Error Codes. **Appendix B** provides Software Installation Instructions.

Conventions Used in the Manual

Special attention should be given to the following symbols for proper installation and to prevent damage done to the components or injury to yourself:



Warning: Important information given to ensure proper system installation or to prevent damage to the components.



Note: Additional Information given to differentiate various models or to ensure correct system setup.

Contacting Supermicro

Headquarters

Address: Super Micro Computer, Inc.
980 Rock Ave.
San Jose, CA 95131 U.S.A.

Tel: +1 (408) 503-8000

Fax: +1 (408) 503-8008

Email: marketing@supermicro.com (General Information)
support@supermicro.com (Technical Support)

Web Site: www.supermicro.com

Europe

Address: Super Micro Computer B.V.
Het Sterrenbeeld 28, 5215 ML
's-Hertogenbosch, The Netherlands

Tel: +31 (0) 73-6400390

Fax: +31 (0) 73-6416525

Email: sales@supermicro.nl (General Information)
support@supermicro.nl (Technical Support)
rma@supermicro.nl (Customer Support)

Asia-Pacific

Address: Super Micro Computer, Inc.
4F, No. 232-1, Liancheng Rd.
Chung-Ho 235, Taipei County
Taiwan, R.O.C.

Tel: +886-(2) 8226-3990

Fax: +886-(2) 8226-3991

Web Site: www.supermicro.com.tw

Email: support@supermicro.com.tw (Technical Support)

Tel: +886-(2) 8226-5990 (Technical Support)

Table of Contents

Preface

Chapter 1 Introduction..... 1-1

1-1	Overview	1-1
1-2	Processor and Chipset Overview.....	1-11
1-3	Special Features	1-12
1-4	PC Health Monitoring.....	1-12
1-5	ACPI Features.....	1-13
1-6	Power Supply	1-13
1-7	Super I/O.....	1-14

Chapter 2 Installation..... 2-1

2-1	Static-Sensitive Devices.....	2-1
	Precautions	2-1
	Unpacking	2-1
2-2	Processor and Heatsink Installation.....	2-2
	Installing a CPU Heatsink	2-4
2-3	Mounting the Motherboard into the Chassis.....	2-6
	Tools Needed	2-6
	Installation Instructions.....	2-6
2-4	Installing and Removing the Memory Modules.....	2-7
	Installing & Removing DIMMs.....	2-7
2-5	Control Panel Connectors/IO Ports.....	2-13
	1. Back Panel Connectors/IO Ports.....	2-13
	2. Back Panel IO Port and Onboard IO Connection Pin Definitions	2-14
	ATX PS/2 Keyboard and PS/2 Mouse Ports.....	2-14
	Universal Serial Bus (USB).....	2-15
	Serial Ports.....	2-16
	VGA Connector	2-17
	Gigabit LAN (Ethernet) Ports	2-18
	3. Front Control Panel.....	2-19
	4. Front Control Panel Pin Definitions	2-20
	NMI Button	2-20
	Power LED	2-20
	HDD LED.....	2-21
2-6	Connecting Cables.....	2-24
	Processor Power Connector	2-24
	Internal Speaker.....	2-26

	Overheat LED/Fan Fail (JOH1).....	2-26
	Compact Flash Card PWR Connector.....	2-29
2-7	Jumper Settings.....	2-31
	Explanation of Jumpers.....	2-31
	CMOS Clear.....	2-32
	Watch Dog Enable/Disable.....	2-32
	VGA Enable/Disable.....	2-33
2-8	Onboard Indicators.....	2-35
2-9	Floppy Drive, SIMLP, Serial ATA and HDD Connections.....	2-36
	Serial ATA Ports.....	2-37
	SIMLP IPMI Slot.....	2-37
	Chapter 3 Troubleshooting.....	3-1
3-1	Troubleshooting Procedures.....	3-1
	Before Power On.....	3-1
	No Power.....	3-1
	No Video.....	3-2
	Losing the System's Setup Configuration.....	3-2
	Memory Errors.....	3-2
3-2	Technical Support Procedures.....	3-3
3-3	Frequently Asked Questions.....	3-3
3-4	Returning Merchandise for Service.....	3-4
	Chapter 4 BIOS.....	4-1
4-1	Introduction.....	4-1
	Starting BIOS Setup Utility.....	4-1
	How To Change the Configuration Data.....	4-2
	Starting the Setup Utility.....	4-2
4-2	Main Setup.....	4-2
4-3	Advanced Setup Configurations.....	4-4
4-4	Security Settings.....	4-23
4-5	Boot Configuration.....	4-24
4-6	Exit Options.....	4-26
	Appendix A BIOS Error Beep Codes.....	A-1
A-1	BIOS Error Beep Codes.....	A-1
	Appendix B Software Installation Instructions.....	B-1
B-1	Installing Software Programs.....	B-1
B-2	Configuring Supero Doctor III Settings.....	B-2

Notes

Chapter 1

Introduction

1-1 Overview

Checklist

Congratulations on purchasing your computer motherboard from an acknowledged leader in the industry. Supermicro boards are designed with the utmost attention to detail to provide you with the highest standards in quality and performance. Check that the following items have all been included with your motherboard. If anything listed here is damaged or missing, contact your retailer.

The following items are included in the retail box.

- One (1) Supermicro Mainboard
- One (1) ribbon cable for IDE devices (CBL-0036L-03)
- One (1) floppy ribbon cable (CBL-0022L)
- One (1) COM-port cable (CBL-010L)
- One (1) 2-port USB 2.0 cable (CBL-0083L)
- Six (6) Serial ATA cables (CBL-0044Lx6)
- One (1) I/O backpanel shield (CSE-PT07L)
- One (1) Supermicro CD containing drivers and utilities
- One (1) User's/BIOS Manual

SUPER X8DTN+/X8DTN+-LR Image

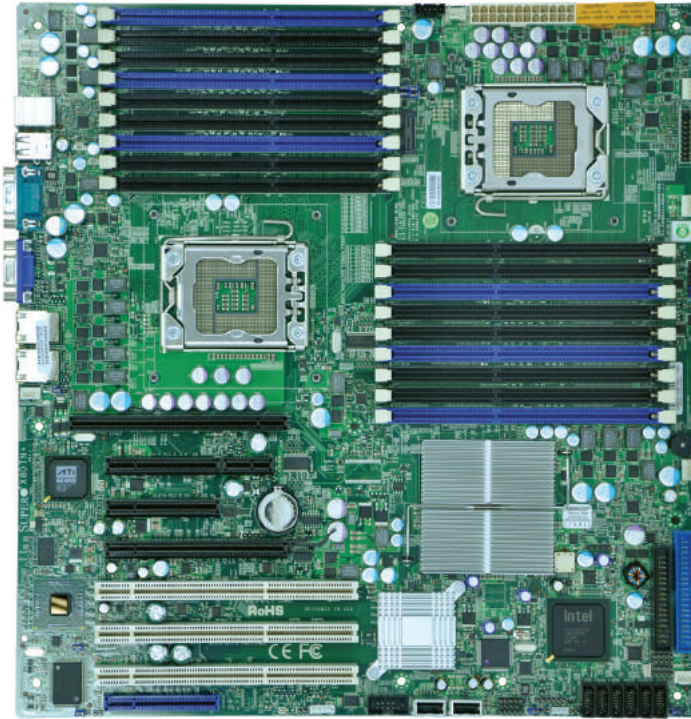

 **Note:** The drawings and pictures shown in this manual were based on the latest PCB Revision available at the time of publishing of the manual. The motherboard you've received may or may not look exactly the same as the graphics shown in the manual.

SUPER[®] X8DTN+/X8DTN+-LR Motherboard Layout

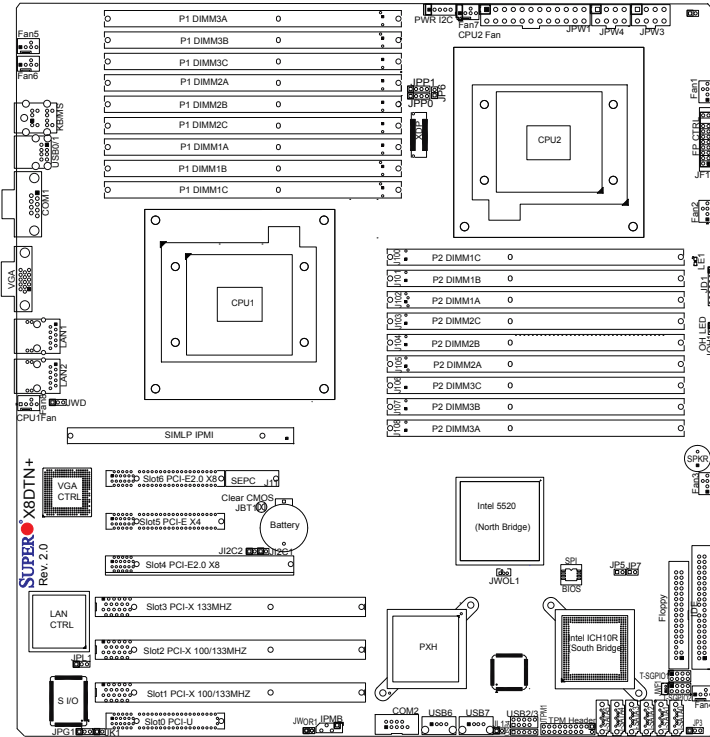

SUPER X8DTN+/X8DTN+-LR Quick Reference

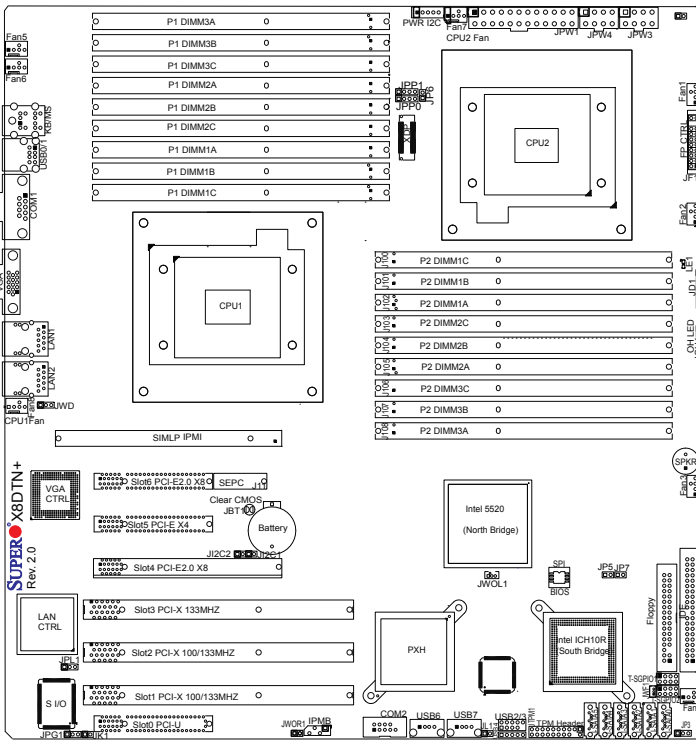

Notes:

1. Jumpers not indicated are for internal testing only.
2. See Chapter 2 for detailed information on jumpers, I/O ports and JF1 front panel connections.
3. "■" indicates the location of Pin 1.
4. When LE1 LED is on, the onboard power connection is on. Make sure to unplug the power cables before removing or installing components.



Warning! 1. To prevent damage to your power supply or motherboard, please use a power supply that contains a 24-pin and two 8-pin power connectors. Be sure to connect these power connectors to the 24-pin and the two 8-pin power connectors on your motherboard for adequate power supply to your system. Failure to do so will void the manufacturer warranty on your power supply and motherboard.

2. To avoid possible system overheating, be sure to provide adequate airflow to the system.

X8DTN+/X8DTN+-LR Quick Reference

Jumper	Description	Default Setting
JBT1	CMOS Clear	(See Section 5-10)
JWD	Watch Dog Enable	Pins 1-2 (Reset)
J ² C1/J ² C2	SMB to PCI-Exp./ SMB to PCI-X Slots	Open (Disabled)
JP3	IDE Enable	1-2 (Normal)
JPG1	VGA Enable	1-2 (Enable)
JPL1	LAN1/2 Enable	Pins 1-2 (Enabled)

Connector	Description
COM1/COM2	COM1/COM2 Serial Port/Header
FAN 1-8	System/CPU Fan Headers (Fans 7/8: CPU Fans)
Floppy	Floppy Disk Drive Connector
IPMB (J14)	IPMB I ² C Header (for an IPMI card)
I-SATA0 ~ I-SATA5	(Intel South Bridge) SATA Ports
JD1	PWR LED/Speaker Header (Pins1~3: PWR LED, 4~7: SPKR)
JF1	Front Panel Connector
JL1	Chassis Intrusion Header
JOH1	Overheat LED Header
JPW1	24-pin ATX Main Power Connector (Required)
JPW3/JPW4	8-pin 12-V Power Connectors (Required. See Page1-4)
JTPM1	TPM (Trusted Platform Module) Header
JWF1	Compact Flash Power Connector
JWOL1	Wake-On-LAN Header
LAN1/2	Gigabit Ethernet (RJ45) Ports
PWR I ² C (J15)	Power SMB (I ² C) Header
SIMLP	(Low Profile) SIMLP IPMI 2.0 Socket
SP1	Internal Buzzer
T-SGPIO-1/T-SGPIO-2	Serial General Purpose Input/Output Headers
(B/P) USB0/1	(Back Panel) Universal Serial Bus (USB) Ports
(F/P) USB 2/3, 4, 6, 7	Front Panel Accessible USB Headers

LED	Description
LE1	Onboard Standby PWR warning LED Indicator

Motherboard Features

CPU

- Two Intel® 5500/5600 Series (LGA 1366) processors, each processor supporting two full-width Intel QuickPath Interconnect (QPI) links with a total of up to 51.2 GB/s Data Transfer Rate (6.4 GB/s per direction)

Memory

• RDIMM

- 240-pin Reg. DDR3 ECC 1333/1066/800 MHz memory with support of up to 288 GB in 18 slots



Note 1. 240-pin Dual Rank (DR) 16 GB Reg. ECC DDR3 1333/1066/800 MHz memory will support up to 288 GB. Memory speed will be downgraded to 800 MHz. (Refer to the notes in the memory configuration tables in Chapter 2.)

Note 2. 240-pin Quad Rank (QR) 16 GB Reg. ECC DDR3 1066/800 MHz memory will support up to 192 GB (with 6 DIMMs max. per CPU). Memory speed will be downgraded to 800 MHz. (Refer to the notes in memory configuration tables in Chapter 2.)

• LRDIMM (Load Reduced DIMM, for X8DTN+-LR Only)

- LRDIMM DDR3 ECC 1066 MHz memory with support of up to 288 GB in 18 slots



Warning: For your system memory to work properly, be sure to use the correct BIOS ROM for your system. For the X8DTN+, use the X8DTN+ BIOS. For the X8DTN+-LR, use the X8DTN+-LR BIOS. To flash the BIOS, refer to http://www.supermicro.com/products/motherboard/QPI/5500/X8DTN_.cfm?IPMI=Y.

• UDIMM

Unbuffered ECC/Non-ECC DDR3 1333/1066/800 MHz memory of up to 48 GB memory

Chipset

- Intel 5520 chipset, including: the 5520 (North Bridge) and the ICH10R (South Bridge).

Expansion Slots

- Two PCI-E 2.0 x8 slot (Slot4/Slot6)
- One PCI-E x4 (in x8 slot) (Slot5)
- Two PCI-X 100MHz/133MHz slots (Slot2/Slot3)

- One PCI-X 133MHz slots (Slot1)
- One PCI-U (UIO) Slot (Slot0)
- SEPC (Supermicro PCI-E Power Connector) Slot (J11)
- One SIMLP IPMI Slot

BIOS

- 32 Mb AMI SPI Flash ROM
- PCI 2.2, ACPI 1.0/2.0/3.0, Plug and Play (PnP), DMI 2.3, USB Keyboard support, and SMBIOS 2.3

PC Health Monitoring

- Onboard voltage monitors for CPU1 Vcore, CPU2 Vcore, +5Vin, +12V, -12V 3.3Vcc (V), and Battery Voltage
- Fan status monitor with firmware control
- CPU/chassis temperature monitors
- Platform Environment Control Interface (PECI) ready
- Thermal Monitor 2 (TM2) support
- CPU fan auto-off in sleep mode
- CPU slow-down on temperature overheat
- Pulse Width Modulation (PWM) Fan Control
- CPU thermal trip support for processor protection, power LED
- Power-up mode control for recovery from AC power loss
- Auto-switching voltage regulator for CPU cores
- System overheat/Fan Fail LED Indicator and control
- Chassis intrusion detection
- System resource alert via Supero Doctor III

ACPI Features

- Slow blinking LED for suspend state indicator
- Main switch override mechanism
- ACPI Power Management

Onboard I/O

- Intel ICH10R supports six SATA2 ports (with RAID0, RAID1, RAID10, RAID5 supported in the Windows OS Environment)
- One SIMLP IPMI socket
- Intel 82576 dual-LAN Gigabit Ethernet controller supports dual Giga-bit LAN ports
- One EIDE Ultra DMA/100 bus master interface
- One floppy port interface

- Two COM ports(1 header, 1 port)
- PS/2 mouse and PS/2 keyboard ports
- Up to seven USB 2.0 (Universal Serial Bus) (2 Ports, 2 Front Headers, and 2 Type A Headers)
- Super I/O: Winbond W83627HF
- ATI ES1000 32Mb VGA Controller supports one VGA port

Other

- Console redirection
- Onboard Fan Speed Control by Thermal Management via BIOS

CD/Diskette Utilities

- BIOS flash upgrade utility and device drivers

Dimensions

- Ext. ATX 13.68" (L) x 13" (W) (347.47 mm x 330.20 mm)

Notes

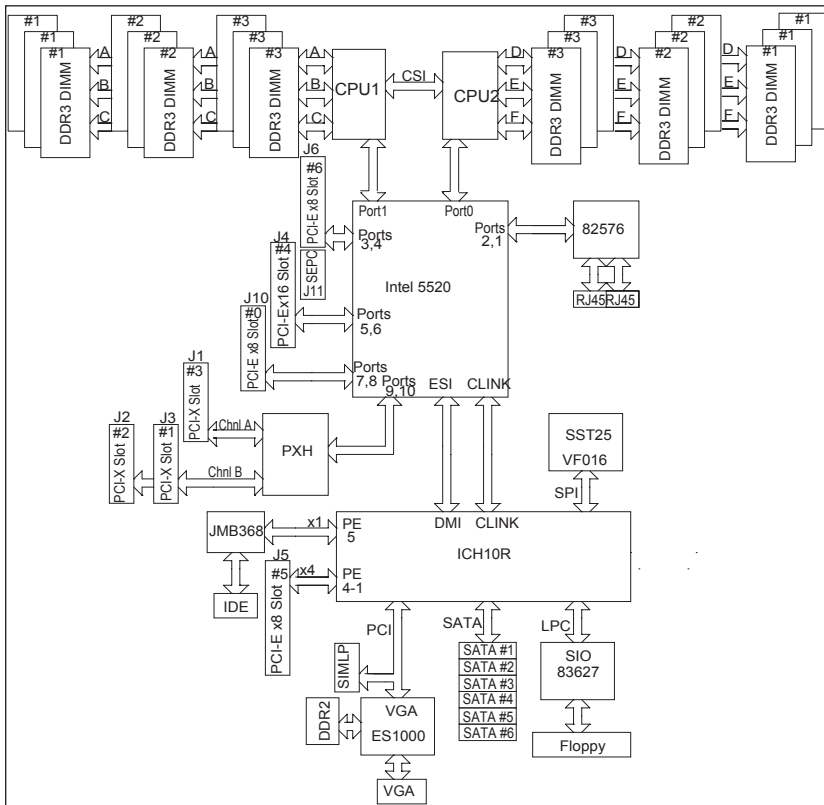

Block Diagram of the 5520 Platform

 **Note:** This is a general block diagram. Please see the previous Motherboard Features pages for details on the features of each motherboard.

1-2 Processor and Chipset Overview

Built upon the functionality and the capability of the 5500/5600 Series Processor platform, the X8DTN+/X8DTN+-LR motherboard provides the performance and feature set required for dual-processor-based high-end systems with configuration optimized for intensive application and high-end server platforms. The 5500/5600 Series Processor platform consists of the 5500/5600 Series (LGA 1366) processor, the 5520 (North Bridge), and the ICH10R (South Bridge). With the Intel QuickPath Interconnect (QPI) controller built in, the 5500/5600 Series Processor platform is the first dual-processing platform to offer the next generation point-to-point system interconnect interface that replaces the current Front Side Bus Technology and substantially enhances system performance by utilizing serial link interconnections, allowing for increased bandwidth and scalability.

The 5520 connects to each processor through an independent QuickPath Interconnect link. Each link consists of 20 pairs of uni-directional differential lanes for transmission and receiving in addition to a differential forwarded clock. A full-width QPI link pair provides 84 signals. Each processor supports two QuickPath link, one going to the other processor and the other to the 5520.

The 5520 supports up to 36 PCI Express Gen2 lanes, peer-to-peer read and write transactions. The ICH10R supports up to 6 PCI-Express ports, six SATA ports and 10 USB connections.

In addition, the 5500/5600 Series Processor platform also offers a wide range of RAS (Reliability, Availability and Serviceability) features. These features include memory interface ECC, x4/x8 Single Device Data Correction (SDDC), Cyclic Redundancy Check (CRC), parity protection, out-of-band register access via SMBus, memory mirroring, and Hot-plug support on the PCI-Express Interface.

The Main Features of the 5500/5600 Series Processor and the 5520 Chipset

- Four processor cores in each processor with 8MB shared cache among cores
- Two full-width Intel QuickPath interconnect links, up to 6.4 GT/s of data transfer rate in each direction
- Virtualization Technology, Integrated Management Engine supported
- Point-to-point cache coherent interconnect, Fast/narrow unidirectional links, and Concurrent bi-directional traffic
- Error detection via CRC and Error correction via Link level retry

1-3 Special Features

Recovery from AC Power Loss

BIOS provides a setting for you to determine how the system will respond when AC power is lost and then restored to the system. You can choose for the system to remain powered off (in which case you must hit the power switch to turn it back on) or for it to automatically return to a power-on state. See the Advanced BIOS Setup section to change this setting. The default setting is **Last State**.

1-4 PC Health Monitoring

This section describes the PC health monitoring features of the X8DTN+/X8DTN+-LR. All have an onboard System Hardware Monitor chip that supports PC health monitoring. An onboard voltage monitor will scan these onboard voltages continuously: CPU1 Vcore, CPU2 Vcore, +5Vin, +12V, -12V 3.3Vcc (V), and Battery Voltage. Once a voltage becomes unstable, a warning is given or an error message is sent to the screen. Users can adjust the voltage thresholds to define the sensitivity of the voltage monitor.

Fan Status Monitor with Firmware Control

The PC health monitor can check the RPM status of the cooling fans. The onboard CPU and chassis fans are controlled by Thermal Management via BIOS (under Hardware Monitoring in the Advanced Setting).

Environmental Temperature Control

The thermal control sensor monitors the CPU temperature in real time and will turn on the thermal control fan whenever the CPU temperature exceeds a user-defined threshold. The overheat circuitry runs independently from the CPU. Once it detects that the CPU temperature is too high, it will automatically turn on the thermal fan control to prevent any overheat damage to the CPU. The onboard chassis thermal circuitry can monitor the overall system temperature and alert users when the chassis temperature is too high.



Warning! To avoid possible system overheating, be sure to provide adequate airflow to the system.

System Resource Alert

This feature is available when used with Supero Doctor III in the Windows OS environment or used with Supero Doctor II in Linux. Supero Doctor is used to

notify the user of certain system events. For example, you can also configure Supero Doctor to provide you with warnings when the system temperature, CPU temperatures, voltages and fan speeds go beyond a pre-defined range.

1-5 ACPI Features

ACPI stands for Advanced Configuration and Power Interface. The ACPI specification defines a flexible and abstract hardware interface that provides a standard way to integrate power management features throughout a PC system, including its hardware, operating system and application software. This enables the system to automatically turn on and off peripherals such as CD-ROMs, network cards, hard disk drives and printers.

In addition to enabling operating system-directed power management, ACPI provides a generic system event mechanism for Plug and Play and an operating system-independent interface for configuration control. ACPI leverages the Plug and Play BIOS data structures while providing a processor architecture-independent implementation that is compatible with Windows XP/Windows 2003/Windows 2008/Windows Vista Operating Systems.

Slow Blinking LED for Suspend-State Indicator

When the CPU goes into a suspend state, the chassis power LED will start blinking to indicate that the CPU is in suspend mode. When the user presses any key, the CPU will wake-up and the LED will automatically stop blinking and remain on.

Main Switch Override Mechanism

When an ATX power supply is used, the power button can function as a system suspend button to make the system enter a SoftOff state. The monitor will be suspended and the hard drive will spin down. Pressing the power button again will cause the whole system to wake-up. During the SoftOff state, the ATX power supply provides power to keep the required circuitry in the system "alive." In case the system malfunctions and you want to turn off the power, just press and hold the power button for 4 seconds. This option can be set in the Power section of the BIOS Setup routine.

1-6 Power Supply

As with all computer products, a stable power source is necessary for proper and reliable operation. It is even more important for processors that have high CPU clock rates.

The X8DTN+/X8DTN+-LR can accommodate 24-pin ATX power supplies. Although most power supplies generally meet the specifications required by the CPU, some are inadequate. In addition, the 12V 8-pin power connections are also required to ensure adequate power supply to the system. Also your power supply must supply 1.5A for the Ethernet ports.



Warning: To prevent damage to your power supply or motherboard, please use a power supply that contains a 24-pin and two 8-pin power connectors. Be sure to connect these power connectors to the 24-pin and the two 8-pin power connectors on your motherboard for adequate power supply to your system. Failure to do so will void the manufacturer warranty on your power supply and motherboard.

It is strongly recommended that you use a high quality power supply that meets ATX power supply Specification 2.02 or above. It must also be SSI compliant (For more information, please refer to the web site at <http://www.ssiforum.org/>). Additionally, in areas where noisy power transmission is present, you may choose to install a line filter to shield the computer from noise. It is recommended that you also install a power surge protector to help avoid problems caused by power surges.

1-7 Super I/O

The disk drive adapter functions of the Super I/O chip include a floppy disk drive controller that is compatible with industry standard 82077/765, a data separator, write pre-compensation circuitry, decode logic, data rate selection, a clock generator, drive interface control logic and interrupt and DMA logic. The wide range of functions integrated onto the Super I/O greatly reduces the number of components required for interfacing with floppy disk drives. The Super I/O supports 360 K, 720 K, 1.2 M, 1.44 M or 2.88 M disk drives and data transfer rates of 250 Kb/s, 500 Kb/s or 1 Mb/s. It also provides two high-speed, 16550 compatible serial communication ports (UARTs). Each UART includes a 16-byte send/receive FIFO, a programmable baud rate generator, complete modem control capability and a processor interrupt system. Both UARTs provide legacy speed with baud rate of up to 115.2 Kbps as well as an advanced speed with baud rates of 250 K, 500 K, or 1 Mb/s, which support higher speed modems.

The Super I/O provides functions that comply with ACPI (Advanced Configuration and Power Interface), which includes support of legacy and ACPI power management through an SMI or SCI function pin. It also features auto power management to reduce power consumption.

Chapter 2

Installation

2-1 Static-Sensitive Devices

Electrostatic Discharge (ESD) can damage electronic components. To prevent damage to your system board, it is important to handle it very carefully. The following measures are generally sufficient to protect your equipment from ESD.

Precautions

- Use a grounded wrist strap designed to prevent static discharge.
- Touch a grounded metal object before removing the board from the antistatic bag.
- Handle the board by its edges only; do not touch its components, peripheral chips, memory modules or gold contacts.
- When handling chips or modules, avoid touching their pins.
- Put the motherboard and peripherals back into their antistatic bags when not in use.
- For grounding purposes, make sure your computer chassis provides excellent conductivity between the power supply, the case, the mounting fasteners and the motherboard.
- Use only the correct type of onboard CMOS battery as specified by the manufacturer. Do not install the onboard battery upside down to avoid possible explosion.

Unpacking

The motherboard is shipped in antistatic packaging to avoid static damage. When unpacking the board, make sure the person handling it is static protected.

2-2 Processor and Heatsink Installation



When handling the processor package, avoid placing direct pressure on the label area of the fan.

Notes:

1. Always connect the power cord last and always remove it before adding, removing or changing any hardware components. Make sure that you install the processor into the CPU socket before you install the CPU heatsink.
2. Make sure to install the motherboard into the chassis before you install the CPU heatsink and heatsink fans.
3. When purchasing a 5500/5600 Series processor or when receiving a motherboard with a 5500/5600 Series processor pre-installed, make sure that the CPU plastic cap is in place, and none of the CPU pins are bent; otherwise, contact the retailer immediately.
4. Refer to the MB Features Section for more details on CPU support

Installing an LGA 1366 Processor

1. Press the socket clip to release the load plate, which covers the CPU socket, from its locking position.
2. Gently lift the socket clip to open the load plate.
3. Hold the plastic cap at its north and south center edges to remove it from the CPU socket.

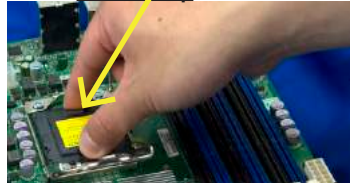
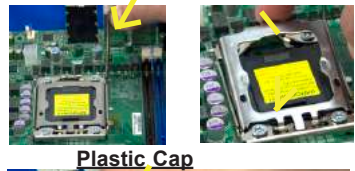
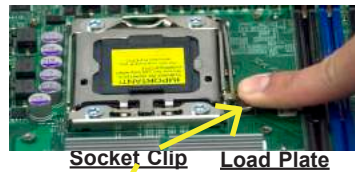

4. After removing the plastic cap, using your thumb and the index finger, hold the CPU at the north and south center edges.
5. Align the CPU key, the semi-circle cutout, against the socket key, the notch below the gold color dot on the side of the socket.
6. Once both the CPU and the socket are aligned, carefully lower the CPU straight down into the socket. (Do not rub the CPU against the surface of the socket or its pins to avoid damaging the CPU or the socket.)
7. With the CPU inside the socket, inspect the four corners of the CPU to make sure that the CPU is properly installed.
8. Once the CPU is securely seated on the socket, lower the CPU load plate to the socket.
9. Use your thumb to gently push the socket clip down to the clip lock.



Warning: Please save the plastic cap. The motherboard must be shipped with the plastic cap properly installed to protect the CPU socket pins. Shipment without the plastic cap properly installed will cause damage to the socket pins.

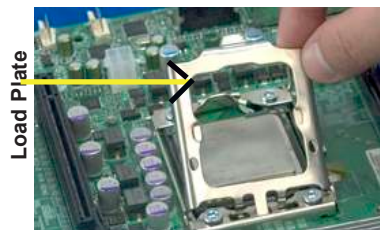
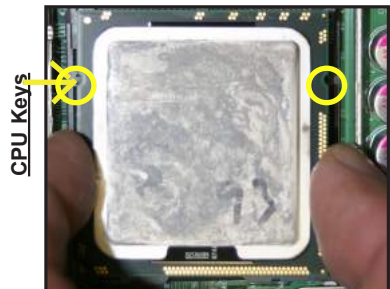
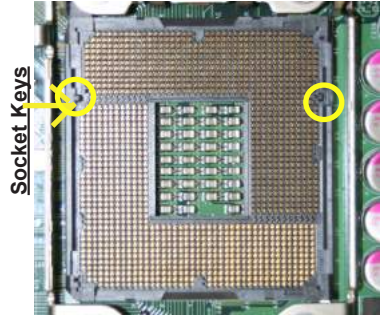
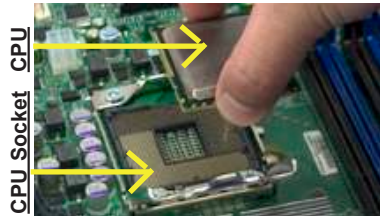

Installing a CPU Heatsink

1. Do not apply any thermal grease to the heatsink or the CPU die because the required amount has already been applied.

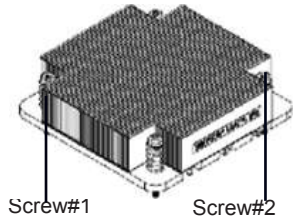

2. Place the heatsink on top of the CPU so that the four mounting holes are aligned with those on the retention mechanism.

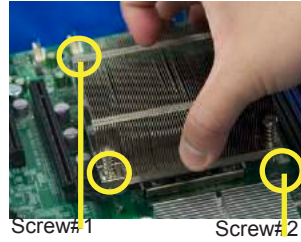

3. Install two diagonal screws (ie the #1 and the #2 screws) and tighten them until just snug (-do not fully tighten the screws to avoid possible damage to the CPU.)

Install Screw#1

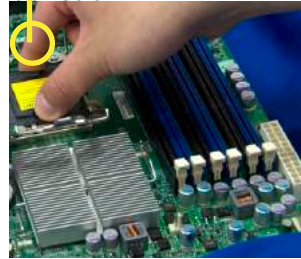

4. Finish the installation by fully tightening all four screws.

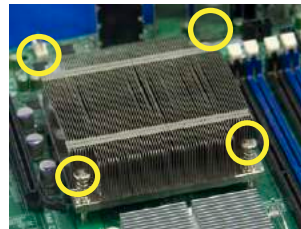

Removing the Heatsink



Warning: We do not recommend that the CPU or the heatsink be removed. However, if you do need to remove the heatsink, please follow the instructions below to uninstall the heatsink and prevent damage to the CPU or other components.

1. Unplug the power cord from the power supply.
2. Disconnect the heatsink fan wires from the CPU fan header.
3. Using a screwdriver, loosen and remove the heatsink screws from the motherboard in the sequence as show in the picture on the right.
4. Hold the heatsink as shown in the picture on the right and gently wriggle the heatsink to loosen it from the CPU. (Do not use excessive force when wriggling the heatsink.)
5. Once the CPU is loosened, remove the heatsink from the CPU socket.
6. To reinstall the CPU and the heatsink, clean the surface of the CPU and the heatsink to get rid of the old thermal grease. Reapply the proper amount of thermal grease on the surface before reinstalling them on the motherboard.

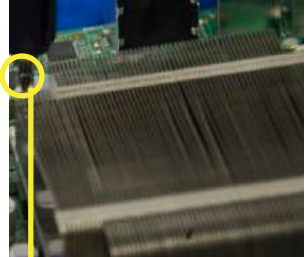

Using a screwdriver to remove Screw#1

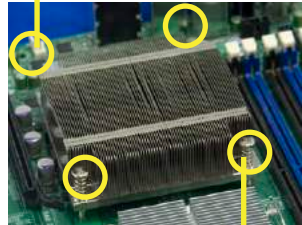

Remove Screw#2



2-3 Mounting the Motherboard into the Chassis

All motherboards have standard mounting holes to fit different types of chassis. Make sure that the locations of all mounting holes for the motherboard and the chassis match. Although a chassis may have both plastic and metal mounting fasteners, metal ones are highly recommended because they ground the motherboard to the chassis. Make sure that the metal standoffs click in or are screwed in tightly. Then use a screwdriver to secure the motherboard onto the motherboard tray. (See the layout on the right for mounting hole locations.)

 **Note:** Some components are very close to the mounting holes. Please take all necessary precautionary measures to avoid damaging these components when installing the motherboard into the chassis.

Locations of Mounting Holes

Tools Needed

1. Phillips Screwdriver





2. Pan head #6 screws

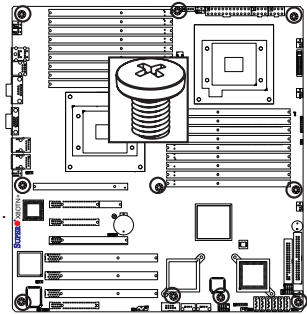

Installation Instructions

1. Install the IO shield into the chassis.
2. Locate the mounting holes on the motherboard. Refer to the layout above for mounting hole locations.
3. Locate the matching mounting holes on the chassis. Align the mounting holes on the motherboard against the mounting holes on the chassis.
4. Install standoffs in the chassis as needed.
5. Install the motherboard into the chassis carefully to avoid damage to motherboard components.



 **Warning:** To avoid damaging the motherboard and its components, please do not apply any force greater than 8 *lb/sq.in* (8 lbs. per square inch) when installing a screw into a mounting hole.

6. Insert a Pan head #6 screw into a mounting hole on the motherboard and its matching mounting hole on the chassis, using a Phillips screwdriver.
7. Repeat Step 4 to insert #6 screws to all mounting holes.
8. Make sure that the motherboard is securely placed on the chassis.

2-4 Installing and Removing the Memory Modules

Note: Check the Supermicro web site for recommended memory modules.



CAUTION

Exercise extreme care when installing or removing DIMM modules to prevent any possible damage.

Installing & Removing DIMMs

Press down the release tabs

1. Insert the desired number of DIMMs into the memory slots, starting with P1-DIMM #1A. When populating multiple DIMM modules within a channel, always start with Bank1 first. (For best performance, please use the memory modules of the same type and same speed in the same bank.)

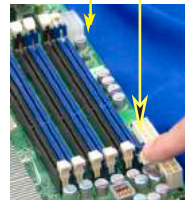

2. Press down the release tabs on the ends of a memory slot. Insert each DIMM module vertically into its slot. Pay attention to the notch along the bottom of the module to prevent inserting the DIMM module incorrectly.
3. Gently press down on the DIMM module until it snaps into place in the slot. Repeat for all modules.

Insert & press down a DIMM module into the slot

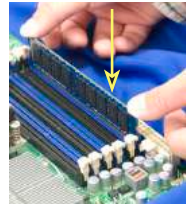

4. Reverse the steps above to remove the DIMM modules from the motherboard.

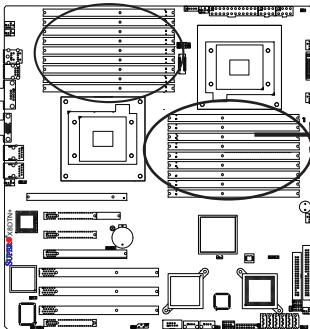

To Remove:

Use your thumbs to gently push the release tabs near both ends of the module. This should release it from the slot.

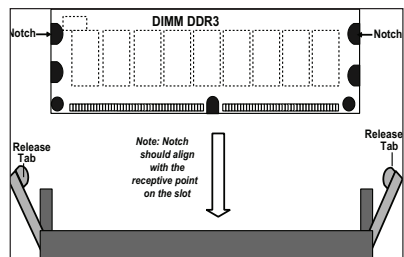

To Install: Insert module vertically and press down until it snaps into place. Pay attention to the alignment notch at the bottom.

Top View of DDR3 Slot

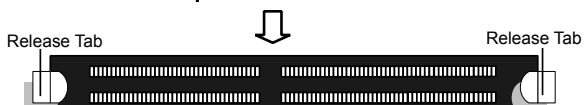

Memory Support

- **RDIMM**

- 240-pin Reg. DDR3 ECC 1333/1066/800 MHz memory with support of up to 288 GB in 18 slots

 **Note 1.** 240-pin Dual Rank (DR) 16 GB Reg. ECC DDR3 1333/1066/800 MHz memory will support up to 288 GB. Memory speed will be downgraded to 800 MHz. (Refer to the notes in the following memory tables.)

Note 2. 240-pin Quad Rank (QR) 16 GB Reg. ECC DDR3 1066/800 MHz memory will support up to 192 GB (with 6 DIMMs max. per CPU). Memory speed will be downgraded to 800 MHz. (Refer to the notes in the following memory tables.)

- **LRDIMM (Load Reduced DIMM, for X8DTN+-LR Only)**

- LRDIMM DDR3 ECC 1066 MHz memory with support of up to 288 GB in 18 slots.



Warning: For your system memory to work properly, be sure to use the correct BIOS ROM for your system. For the X8DTN+, use the X8DTN+ BIOS. For the X8DTN+-LR, use the X8DTN+-LR BIOS. To flash the BIOS, refer to http://www.supermicro.com/products/motherboard/QPI/5500/X8DTN_.cfm?IPMI=Y.

- **UDIMM**

Unbuffered ECC/Non-ECC DDR3 1333/1066/800 MHz memory of up to 48 GB memory

DIMM Module Population Configuration

For memory to work properly, follow the tables below for memory installation:

Memory Population for Optimal Performance -For a Motherboard with One CPU (CPU1) Installed									
P1-DIMMs	To Populate P1-DIMMs								
	Branch 0			Branch 1			Branch 2		
3 DIMMs	P1-1A			P1-2A			P1-3A		
6 DIMMs	P1-1A	P1-1B		P1-2A	P1-2B		P1-3A	P1-3B	
9 DIMMs (RDIMMs only) (Note)	P1-1A	P1-1B	P1-1C	P1-2A	P1-2B	P1-2C	P1-3A	P1-3B	P1-3C

Note: Max. of 6 UDIMM modules are supported by a CPU.

Memory Population for Optimal Performance -For a Motherboard with One CPU (CPU2) Installed									
P2-DIMMs	To Populate P2-DIMMs								
	Branch 0			Branch 1			Branch 2		
3 DIMMs	P2-1A			P2-2A			P2-3A		
6 DIMMs	P2-1A	P2-1B		P2-2A	P2-2B		P2-3A	P2-3B	
9 DIMMs (RDIMMs only) (Note)	P2-1A	P2-1B	P2-1C	P2-2A	P2-2B	P2-2C	P2-3A	P2-3B	P2-3C

Note: Max. of 6 UDIMM modules are supported by a CPU.

Memory Population for Optimal Performance -For a Motherboard with Two CPUs Installed						
	CPU 1 (To Populate P1-DIMMs)			CPU 2 (To Populate P2-DIMMs)		
	Branch 0	Branch 1	Branch 2	Branch 0	Branch 1	Branch 2
6 DIMMs	P1-1A	P1-2A	P1-3A	P2-1A	P2-2A	P2-3A
12 DIMMs	P1-1A/1B	P1-2A/2B	P1-3A/3B	P2-1A/1B	P2-2A/2B	P2-3A/3B
18 DIMMs (For RDIMMs only) (Note)	P1-1A/1B/1C	P1-2A/2B/2C	P1-3A/3B/3C	P2-1A/1B/1C	P2-2A/2B/2C	P2-3A/3B/3C

Note: Max. of 6 UDIMM modules are supported by a CPU.

Memory Support for the Motherboard with the 5500 Processor(s) Installed

RDIMM Population for the motherboard w/5500 Processors Installed				
DIMM Slots per Channel	DIMMs Populated per Channel	DIMM Type (Reg.= Registered)	Speeds (in MHz)	Ranks per DIMM (any combination; SR=Single Rank, DR=Dual Rank, QR=Quad Rank)
3	1	Reg. DDR3 ECC	800,1066,1333	SR or DR
3	1	Reg. DDR3 ECC	800,1066	QR
3	2	Reg. DDR3 ECC	800,1066	Mixing SR, DR
3	2	Reg. DDR3 ECC	800 (Note)	Mixing SR, DR, QR
3	3	Reg. DDR3 ECC	800 (Note)	Mixing SR, DR

Note: 1066 RDIMMs will run at 800 MHz (-BIOS automatic downgrading)

UDIMM Population for the motherboard w/5500 Processors Installed				
DIMM Slots per Channel	DIMMs Populated per Channel	DIMM Type (Unb.= Unbuffered)	Speeds (in MHz)	Ranks per DIMM (any combination; SR=Single Rank, DR=Dual Rank, QR=Quad Rank)
3	1	Unb. DDR3 ECC/Non-ECC	800,1066,1333	SR or DR
3	2	Unb. DDR3 ECC/Non-ECC	800,1066	Mixing SR, DR
3	3	Not available	Not available	Not available

Memory Support for the Motherboard with the 5600 Processor(s) Installed

- 1.5V DIMMs

1.5V RDIMM Population for the motherboard w/5600 Processors Installed				
DIMM Slots per Channel	DIMMs Populated per Channel	DIMM Type (Reg.=Registered)	Speeds (in MHz)	Ranks per DIMM (any combination; SR=Single Rank, DR=Dual Rank, QR=Quad Rank)
3	1	Reg. DDR3 ECC	800,1066,1333	SR or DR
3	1	Reg. DDR3 ECC	800,1066 (Note 1)	QR
3	2	Reg. DDR3 ECC	800,1066, 1333	Mixing SR, DR
3	2	Reg. DDR3 ECC	800 (Note 2)	Mixing SR, DR, QR
3	3	Reg. DDR3 ECC	800 (Note 2)	Mixing SR, DR

Note 1: 1333 MHz RDIMMs will run at 1066 MHz (-BIOS automatic downgrading).
Note 2: 1333/1066 MHz RDIMMs will run at 800 MHz (-BIOS automatic downgrading).
Note 3: Mixing of 1.35V and 1.5V DIMMs is not recommended.

1.5V LRDIMM Population for the Motherboard w/5600 Processors Installed (for X8DTN+-LR Only)				
DIMM Slots per Channel	DIMMs Populated per Channel	DIMM Type (LR= Load Reduced)	Speeds (in MHz)	Ranks per DIMM (QR=Quad Rank, OR=Octal Rank)
3	1	LR DDR3 ECC	1066	QR or OR
3	2	LR DDR3 ECC	1066	QR or OR
3	3	LR DDR3 ECC	1066	QR

1.5V UDIMM Population for the motherboard w/5600 Processors Installed				
DIMM Slots per Channel	DIMMs Populated per Channel	DIMM Type (Unb.= Unbuffered)	Speeds (in MHz)	Ranks per DIMM (any combination; SR=Single Rank, DR=Dual Rank, QR=Quad Rank)
3	1	Unb. DDR3 ECC/Non-ECC	800,1066,1333	SR or DR
3	2	Unb. DDR3 ECC/Non-ECC	800,1066, 1333	Mixing SR, DR
3	3	Not Available	Not Available	Not Available

Note 1: 1333 MHz for two DIMMs per channel is supported when Unbuf./ECC DIMMs are used.
Note 2: Mixing of 1.35V and 1.5V DIMMs is not recommended.

- 1.35V DIMMs

1.35V RDIMM Population for the motherboard w/5600 Processors Installed				
DIMM Slots per Channel	DIMMs Populated per Channel	DIMM Type (Reg.=Registered)	Speeds (in MHz)	Ranks per DIMM (any combination; SR=Single Rank, DR=Dual Rank, QR=Quad Rank)
3	1	Reg. DDR3 ECC	800,1066,1333	SR or DR
3	1	Reg. DDR3 ECC	800 (Note 1)	QR
3	2	Reg. DDR3 ECC	800,1066 (Note 2)	Mixing SR, DR
3	2	Reg. DDR3 ECC	800 (Note 3)	Mixing SR, DR, QR
3	3	Not Available	Not Available	Not Available
Note 1: 1333/1066 MHz QR RDIMMs will run at 800 MHz (-BIOS automatic downgrading). Note 2: 1333 MHz SR/DR RDIMMs will run at 800 MHz (-BIOS automatic downgrading). Note 3: 1333/1066 MHz SR/DR/QR RDIMMs will run at 800 MHz (-BIOS automatic downgrading). Note 4: Mixing of 1.35V and 1.5V DIMMs is not recommended.				

1.35V UDIMM Population for the motherboard w/5600 Processors Installed				
DIMM Slots per Channel	DIMMs Populated per Channel	DIMM Type (Unb.=Unbuffered)	Speeds (in MHz)	Ranks per DIMM (any combination; SR=Single Rank, DR=Dual Rank, QR=Quad Rank)
3	1	Unb. DDR3 ECC	800,1066,1333	SR or DR
3	2	Unb. DDR3 ECC	800,1066	Mixing SR, DR
3	3	Not Available	Not Available	Not Available
Note 1: 1333 MHz for two DIMMs per channel is supported when Unbuf./ECC DIMMs are used. Note 2: Mixing of 1.35V and 1.5V DIMMs is not recommended.				



Note 1: Due to OS limitations, some operating systems may not show more than 4 GB of memory.

Note 2: Due to memory allocation to system devices, the amount of memory that remains available for operational use will be reduced when 4 GB of RAM is used. The reduction in memory availability is disproportional. (See the following Table.)

Possible System Memory Allocation & Availability		
System Device	Size	Physical Memory Remaining (-Available) (4 GB Total System Memory)
Firmware Hub flash memory (System BIOS)	1 MB	3.99 GB
Local APIC	4 KB	3.99 GB
Area Reserved for the chipset	2 MB	3.99 GB
I/O APIC (4 Kbytes)	4 KB	3.99 GB
PCI Enumeration Area 1	256 MB	3.76 GB
PCI Express (256 MB)	256 MB	3.51 GB
PCI Enumeration Area 2 (if needed) -Aligned on 256-MB boundary-	512 MB	3.01 GB
VGA Memory	16 MB	2.85 GB
TSEG	1 MB	2.84 GB
Memory available for the OS & other applications		2.84 GB

2-5 Control Panel Connectors/IO Ports

The I/O ports are color coded in conformance with the PC 99 specification. See the picture below for the colors and locations of the various I/O ports.

1. Back Panel Connectors/IO Ports

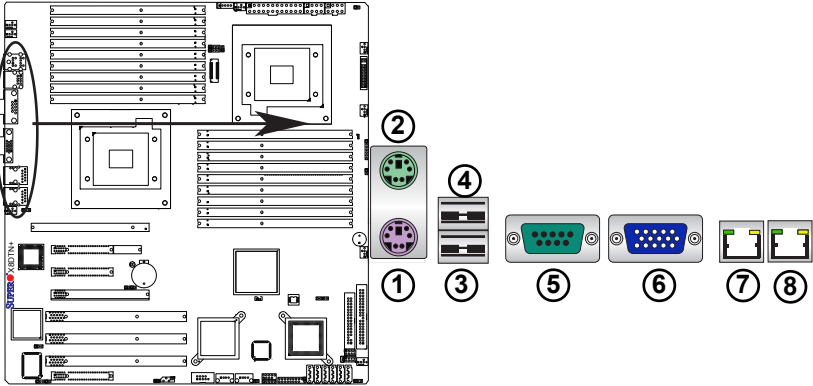

Back Panel I/O Port Locations and Definitions

Back Panel Connectors

1. Keyboard (Purple)
2. PS/2 Mouse (Green)
3. Back Panel USB Port 0
4. Back Panel USB Port 1
5. COM Port 1 (Turquoise)
6. VGA (Blue)
7. Gigabit LAN 1
8. Gigabit LAN 2

2. Back Panel IO Port and Onboard IO Connection Pin Definitions

ATX PS/2 Keyboard and PS/2 Mouse Ports

The ATX PS/2 keyboard and PS/2 mouse (JKM1) are located next to the Backpanel USB ports on the motherboard. See the table at right for pin definitions.

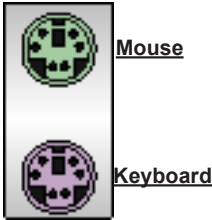

PS/2 Keyboard/Mouse Pin Definitions			
PS2 Keyboard		PS2 Mouse	
Pin#	Definition	Pin#	Definition
1	KB Data	1	Mouse Data
2	NC	2	NC
3	Ground	3	Ground
4	Mouse/KB VCC (+5V)	4	Mouse/KB VCC (+5V)
5	KB Clock	5	Mouse Clock
6	No Connection	6	No Connection

NC: No Connection

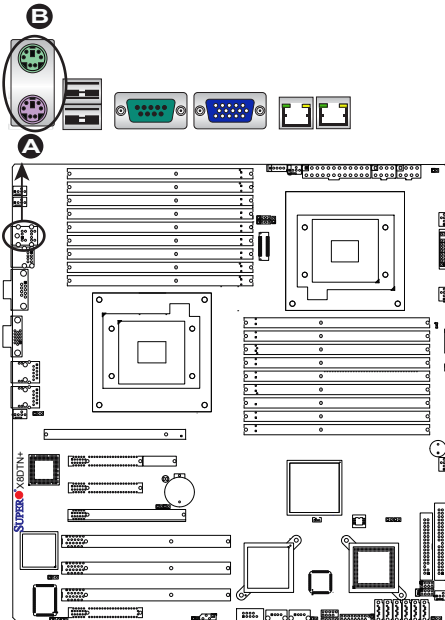

A. Keyboard
B. Mouse

Universal Serial Bus (USB)

There are seven USB 2.0 (Universal Serial Bus) connections on the motherboard. Backpanel USB Ports 0/1 are located at JUSB1. The other five are for front panel access. USB 2/3 (JUSB 2), USB 4 (JUSB 3), USB 6 (J7) and USB 7 (J8) provide front panel USB access. See the tables on the right for pin definitions.

Back Panel USB (USB0/1)	
Pin#	Definitions
1	+5V
2	PO-
3	PO+
4	Ground
5	N/A

Front Panel USB (USB6/7)	
Pin#	Definition
1	Vcc
2	Data-
3	Data+
4	Ground
5	NA

Front Panel USB Pin Definitions (USB2/3/4)			
USB2/4		USB3	
Pin #	Definition	Pin #	Definition
1	+5V	1	+5V
2	PO-	2	PO-
3	PO+	3	PO+
4	Ground	4	Ground
5	Key	5	No connection

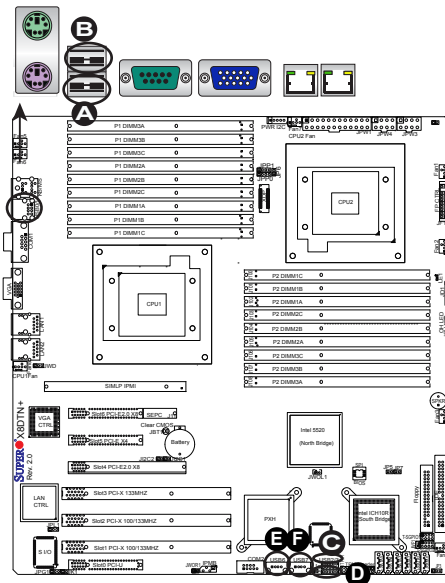

- A. Backpanel USB 0
- B. Backpanel USB 1
- C. Front Panel USB 2/3
- D. Front Panel USB 4
- E. Front Panel USB 6
- F. Front Panel USB 7

Serial Ports

Two COM connections (COM1 & COM2) are located on the motherboard. COM1 is located next to the Video port on the Backplane IO panel. COM2 (JCOM2) is located next to the USB Port 6 to provide front access serial connection. See the table on the right for pin definitions.

Serial Ports-COM1 Pin Definitions			
Pin #	Definition	Pin #	Definition
1	DCD	6	DSR
2	RXD	7	RTS
3	TXD	8	CTS
4	DTR	9	RI
5	Ground	10	N/A

Serial Ports-COM2 Pin Definitions			
Pin #	Definition	Pin #	Definition
1	DCD	6	DSR
2	RXD	7	RTS
3	TXD	8	CTS
4	DTR	9	RI
5	Ground	10	Key

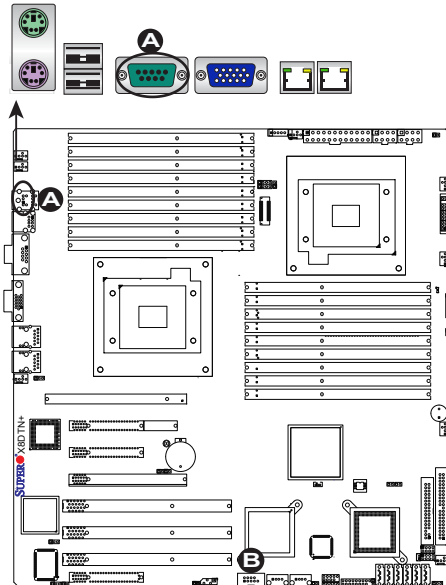

A. COM1

B. COM2

VGA Connector

A VGA connector is located next to COM Port1 on the IO backplane. This connector provides video and CRT display. Refer to the board layout below for the location.

VGA/CRT Pin Definitions			
Pin#	Definition	Pin#	Definition
1	Red	9	NC
2	Green	10	Ground
3	Blue	11	MS0
4	MS2	12	MS1: SDA (DDC Data)
5	Ground	13	HSYNC
6	Ground	14	VSYSNC
7	Ground	15	MS3: SCL (DDC CLK)
8	Ground	16	

NC= No Connection

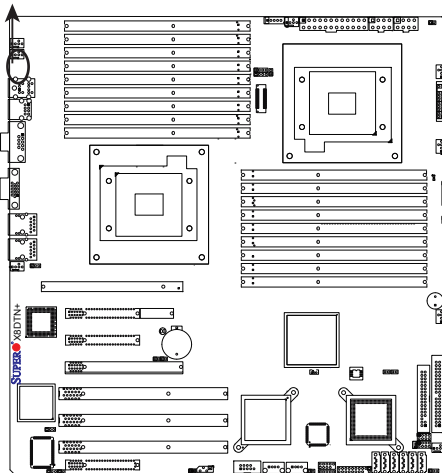
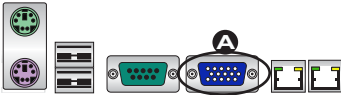

A. VGA

Gigabit LAN (Ethernet) Ports

Two Gigabit Ethernet ports (GLAN1/2) are located at JLAN1/JLAN2 on the IO backplane. These ports accept RJ45 type cables. (**Note:** Please refer to the LED Indicator Section for GLAN LED information.)

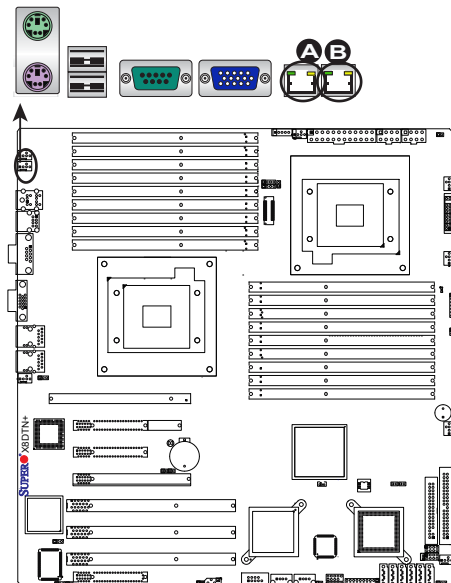
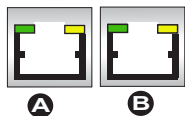

- A. GLAN1
- B. GLAN2

3. Front Control Panel

JF1 contains header pins for various buttons and indicators that are normally located on a control panel at the front of the chassis. These connectors are designed specifically for use with Supermicro server chassis. See the figure below for the descriptions of the various control panel buttons and LED indicators. Refer to the following section for descriptions and pin definitions.

JF1 Header Pins

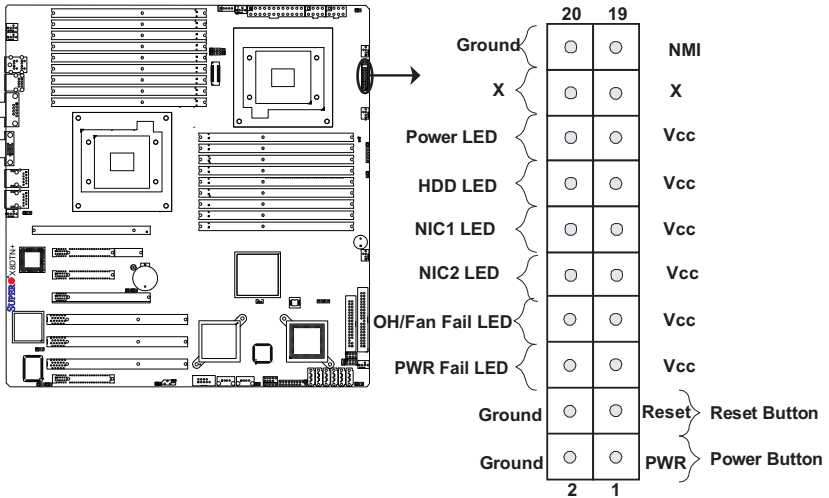

4. Front Control Panel Pin Definitions

NMI Button

The non-maskable interrupt button header is located on pins 19 and 20 of JF1. Refer to the table on the right for pin definitions.

NMI Button Pin Definitions (JF1)	
Pin#	Definition
19	Control
20	Ground

Power LED

The Power LED connection is located on pins 15 and 16 of JF1. Refer to the table on the right for pin definitions.

Power LED Pin Definitions (JF1)	
Pin#	Definition
15	+5V
16	Ground

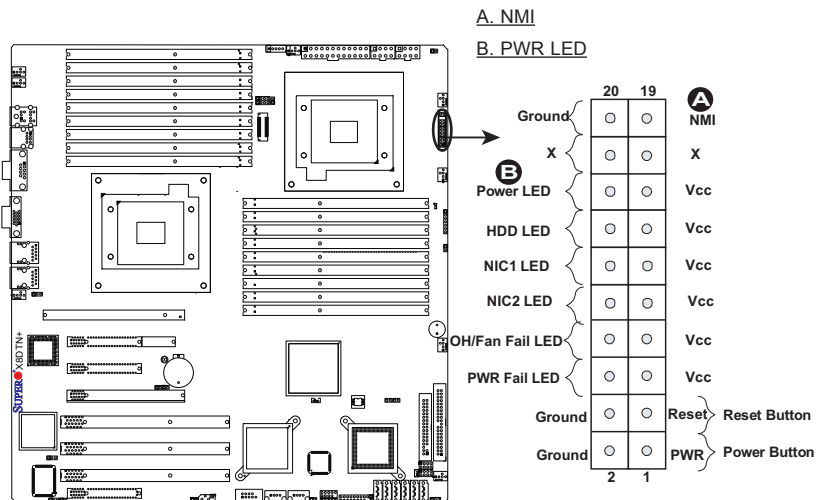

HDD LED

The HDD LED connection is located on pins 13 and 14 of JF1. Attach a hard drive LED cable here to display disk activity (for any hard drive activities on the system, including Serial ATA and IDE). See the table on the right for pin definitions.

HDD LED Pin Definitions (JF1)	
Pin#	Definition
13	+5V
14	HD Active

NIC1/NIC2 LED Indicators

The NIC (Network Interface Controller) LED connection for GLAN port 1 is located on pins 11 and 12 of JF1, and the LED connection for GLAN Port 2 is on Pins 9 and 10. Attach the NIC LED cables to display network activity. Refer to the table on the right for pin definitions.

GLAN1/2 LED Pin Definitions (JF1)	
Pin#	Definition
9/11	Vcc
10/12	Ground

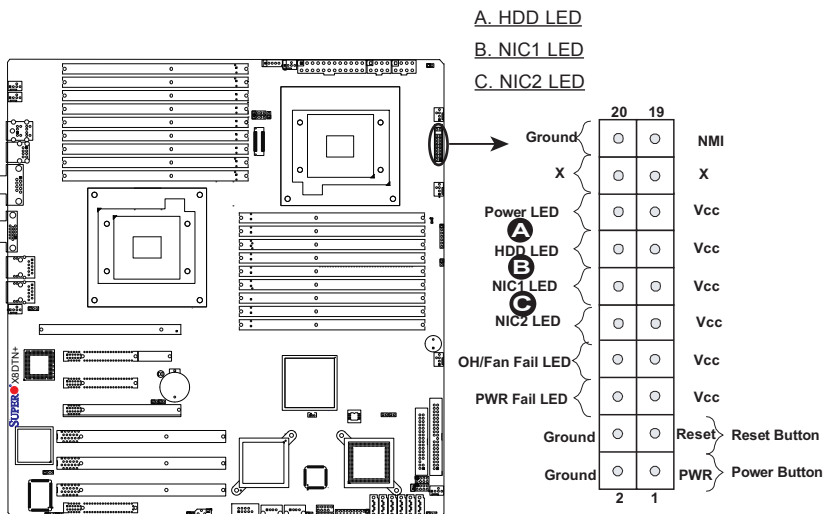

Overheat (OH)/Fan Fail LED

Connect an LED Cable to the OH/ Fan Fail connection on pins 7 and 8 of JF1 to provide an advanced warning of chassis overheating or fan failure. Refer to the table on the right for pin definitions.

OH/Fan Fail LED Pin Definitions (JF1)	
Pin#	Definition
7	Vcc
8	Ground

OH/Fan Fail Indicator Status	
State	Definition
Off	Normal
On	Overheat
Flashing	Fan Fail

Power Fail LED

The Power Fail LED connection is located on pins 5 and 6 of JF1. Refer to the table on the right for pin definitions.

PWR Fail LED Pin Definitions (JF1)	
Pin#	Definition
5	Vcc
6	Ground

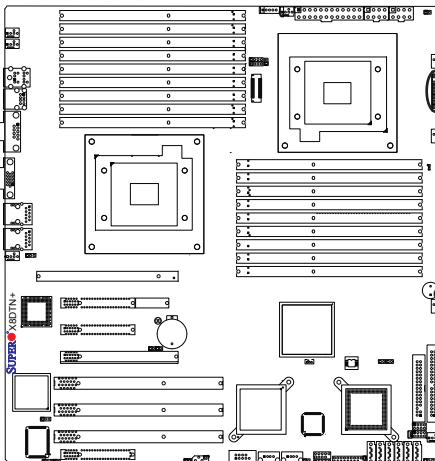

A. OH/Fan Fail LED

B. PWR Supply Fail

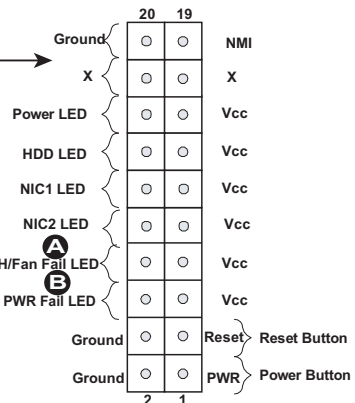

Reset Button

The Reset Button connection is located on pins 3 and 4 of JF1. Attach it to a hardware reset switch on the computer case. Refer to the table on the right for pin definitions.

Reset Button Pin Definitions (JF1)	
Pin#	Definition
3	Reset
4	Ground

Power Button

The Power Button connection is located on pins 1 and 2 of JF1. Momentarily contacting both pins will power on/off the system. This button can also be configured to function as a suspend button (with a setting in the BIOS - see Chapter 4). To turn off the power in the suspend mode, press the button for at least 4 seconds. Refer to the table on the right for pin definitions.

Power Button Pin Definitions (JF1)	
Pin#	Definition
1	Signal
2	+3V Standby

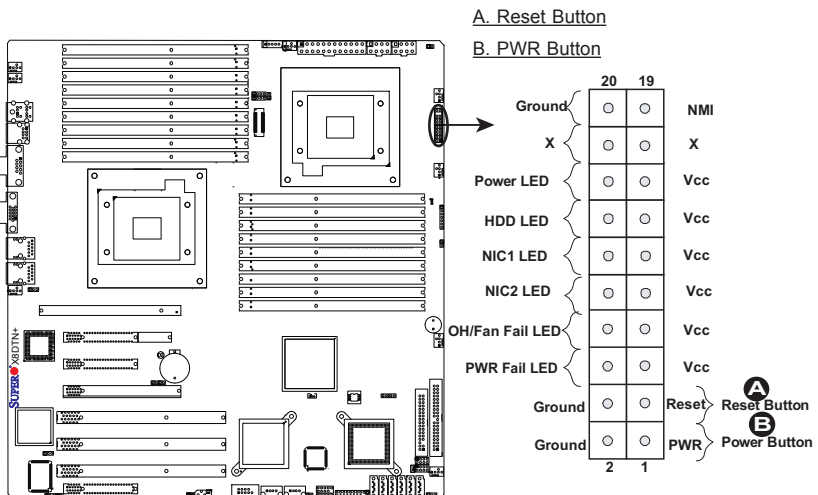

2-6 Connecting Cables

ATX Power Connector

There are a 24-pin main power supply connector(JPW1) and two 8-pin CPU PWR connectors (JPW3/JPW5) on the motherboard. These power connectors meet the SSI EPS 12V specification. For the 8-pin PWR (JPW3/JPW4), please refer to the item listed below.

Processor Power Connector

In addition to the Primary ATX power connector, the 12V 8-pin CPU PWR connectors at JPW3/JPW4 must also be connected to your power supply to ensure adequate power supply to your system. See the table on the right for pin definitions.

Pin#	Definition	Pin #	Definition
13	+3.3V	1	+3.3V
14	-12V	2	+3.3V
15	COM	3	COM
16	PS_ON	4	+5V
17	COM	5	COM
18	COM	6	+5V
19	COM	7	COM
20	Res (NC)	8	PWR_OK
21	+5V	9	5VSB
22	+5V	10	+12V
23	+5V	11	+12V
24	COM	12	+3.3V

Pins	Definition
1 through 4	Ground
5 through 8	+12V

Required



Warning: To prevent damage to your power supply or motherboard, please use a power supply that contains a 24-pin and two 8-pin power connectors. Be sure to connect these power connectors to the 24-pin and the two 8-pin power connectors on your motherboard for adequate power supply to your system. Failure to do so will void the manufacturer warranty on your power supply and motherboard.

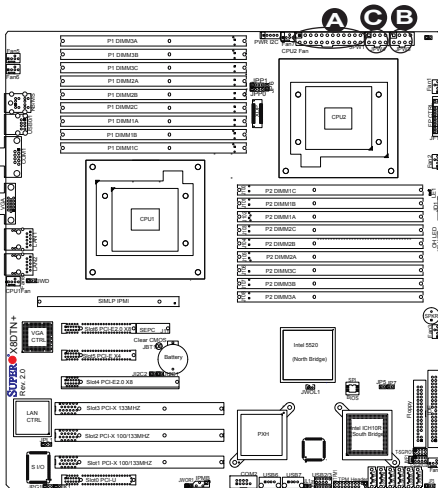

A. 24-pin ATX PWR

B/C. 8-pin Processor PWR

Fan Headers

The X8DTN+/X8DTN+-LR has six chassis/system fan headers (Fan1 to Fan6) and two CPU fans (Fan7/Fan8) on the motherboard. All these 4-pin fans headers are backward compatible with the traditional 3-pin fans. However, 3-pin fans do not support fan speed control. Fan speed control is available for 4-pin fans only. The onboard fan speeds are controlled by Thermal Management via Hardware Monitoring in the Advanced Setting in the BIOS. (The Default setting is Disabled.) See the table on the right for pin definitions.

Fan Header Pin Definitions	
Pin#	Definition
1	Ground
2	+12V
3	Tachometer
4	PWR Modulation

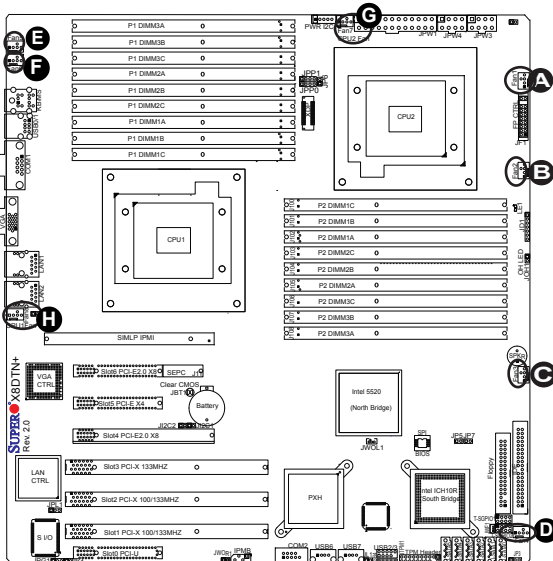

- A. Fan 1
- B. Fan 2
- C. Fan 3
- D. Fan 4
- E. Fan 5
- F. Fan 6
- G. Fan 7 (CPU2 Fan)
- H. Fan 8 (CPU1 Fan)

Internal Speaker

The Internal Speaker, located at SP1, can be used to provide audible indications for various beep codes. See the table on the right for pin definitions. Refer to the layout below for the locations of the Internal Buzzer (SP1).

Internal Buzzer (SP1) Pin Definition		
Pin#	Definitions	
Pin 1	Pos. (+)	Beep In
Pin 2	Neg. (-)	Alarm Speaker

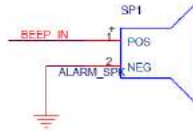

Overheat LED/Fan Fail (JOH1)

The JOH1 header is used to connect an LED indicator to provide warnings of chassis overheat or fan failure. This LED will blink when a fan failure occurs. Refer to the table on right for pin definitions.

Overheat LED Pin Definitions	
Pin#	Definition
1	5vDC
2	OH Active

OH/Fan Fail LED Pin Definitions	
State	Message
Solid	Overheat
Blinking	Fan Fail

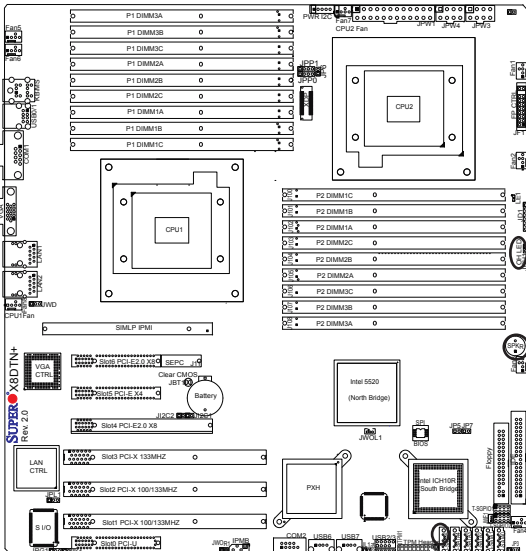

- A. Keyboard/Mouse
- B. Overheat/Fan Fail LED

Chassis Intrusion

A Chassis Intrusion header is located at JL1 on the motherboard. Attach an appropriate cable from the chassis to inform you of a chassis intrusion when the chassis is opened.

Chassis Intrusion Pin Definitions (JL1)

Pin#	Definition
1	Intrusion Input
2	Ground

T-SGPIO Headers

Two SGPIO (Serial-Link General Purpose Input/Output) headers (T-SGPIO-1/T-SGPIO-2) are located below the floppy drive on the motherboard. These headers support serial link interfaces for the onboard SATA connectors. See the table on the right for pin definitions. Refer to the board layout below for the location.

T-SGPIO Pin Definitions

Pin#	Definition	Pin	Definition
1	NC	2	NC
3	Ground	4	Data
5	Load	6	Ground
7	Clock	8	NC

Note: NC= No Connections

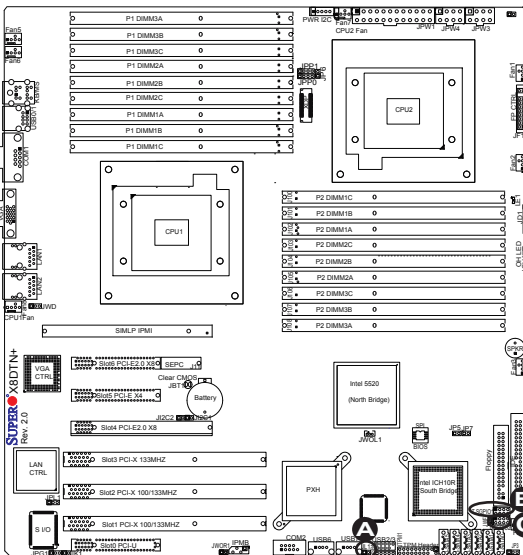

A. Chassis Intrusion

B. T-SGPIO-1

C. T-SGPIO-2

Power SMB (I²C) Connector

Power System Management Bus (I²C) Connector (J15) monitors power supply, fan and system temperatures. See the table on the right for pin definitions.

PWR SMB Pin Definitions	
Pin#	Definition
1	Clock
2	Data
3	PWR Fail
4	Ground
5	+3.3V

IPMB I²C SMB

A System Management Bus header for the IPMI slot is located at J14. Connect the appropriate cable here to use the IPMB I²C connection on your system.

SMB Header Pin Definitions	
Pin#	Definition
1	Data
2	Ground
3	Clock
4	No Connection

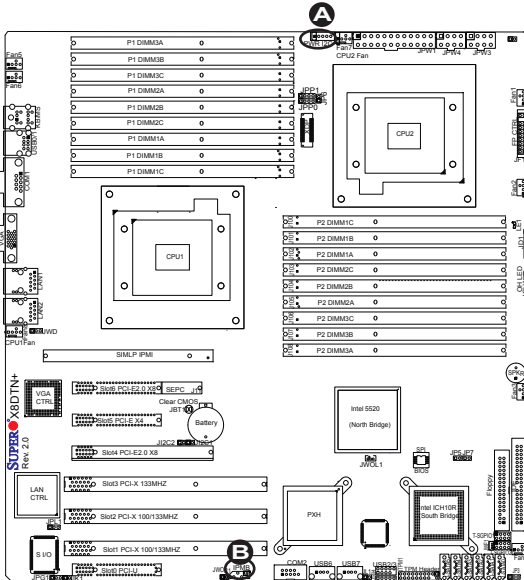

A. PWR SMB

B. IPMB SMB

Compact Flash Card PWR Connector

A Compact Flash Card Power Connector is located at JWF1. For the Compact Flash card to work properly, you will need to first connect the Compact Flash power cable to JWF1. Refer to the board layout below for the location.

Compact Flash Card PWR Connector	
Jumper	Definition
On	Compact Flash Power On (Default)
Off	Compact Flash Power Off

Wake-On-LAN

The Wake-On-LAN header (JWOL1) is located below the Intel ICH10R chip on the motherboard. You must also have a LAN card with a Wake-On-LAN connector and a cable to use this feature. See the table on the right for pin definitions.

Wake-On-LAN Pin Definitions	
Pin#	Definition
1	+5V Standby
2	Ground
3	Wake-up

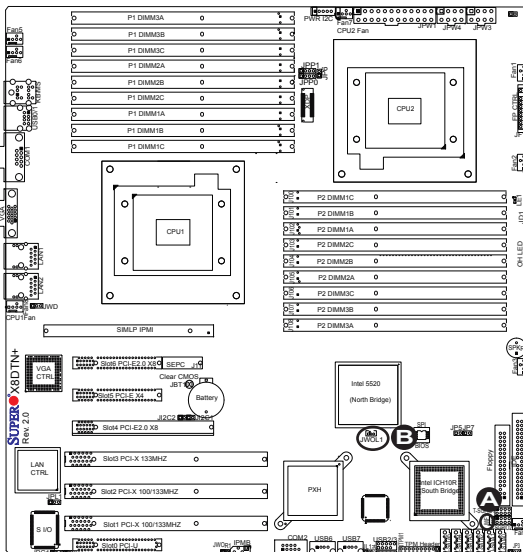

A. Compact Flash PWR

B. WOL

Trusted Platform Module Header

A Trusted Platform Module (TPM) header (JTPM1) is located next to the SATA connectors. This header provides TPM support to ensure data integrity and system security. Refer to the table on the right for pin definitions.

Trusted Platform Module (TPM) Header Pin Definitions			
Pin#	Definition	Pin #	Definition
1	LPC Clock	2	GND
3	LPC FRAME#	4	Key
5	LPC Reset#	6	+5V (X)
7	LAD3	8	LAD2
9	+3.3V	10	LAD1
11	LAD0	12	GND
13	SCL	14	SDAT
15	+3V_DUAL	16	SERIRQ (X)
17	GND	18	CLKRUN(X)
19	LPCPD# (X)	20	LDRQ#(X)

Notes:

(X)=TPM does not use the signals.
 SCL, SDAT are I²C bus clock and data.

A. TPM Header

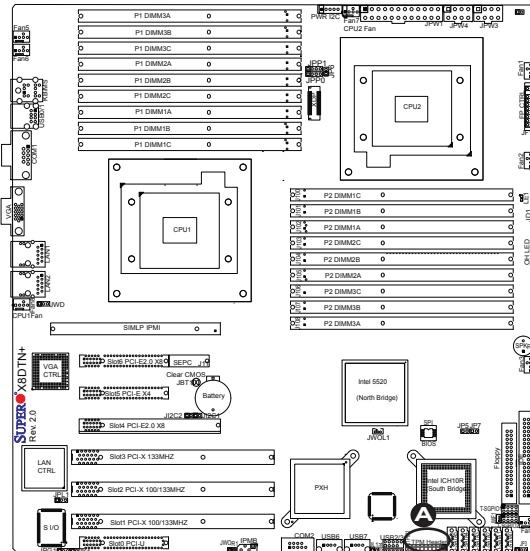

2-7 Jumper Settings

Explanation of Jumpers

To modify the operation of the motherboard, jumpers can be used to choose between optional settings. Jumpers create shorts between two pins to change the function of the connector. Pin 1 is identified with a square solder pad on the printed circuit board. See the motherboard layout pages for jumper locations.

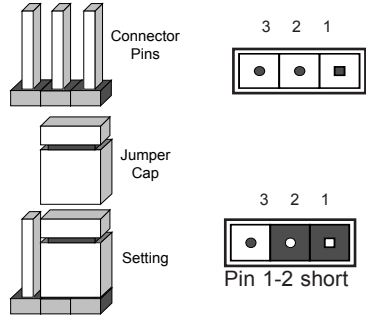

 **Note:** On two pin jumpers, "Closed" means the jumper is on and "Open" means the jumper is off the pins.

GLAN Enable/Disable

JPL1 enables or disables the GLAN Port1/GLAN Port2 on the motherboard. See the table on the right for jumper settings. The default setting is **Enabled**.

GLAN Enable Jumper Settings	
Pin#	Definition
1-2	Enabled (default)
2-3	Disabled

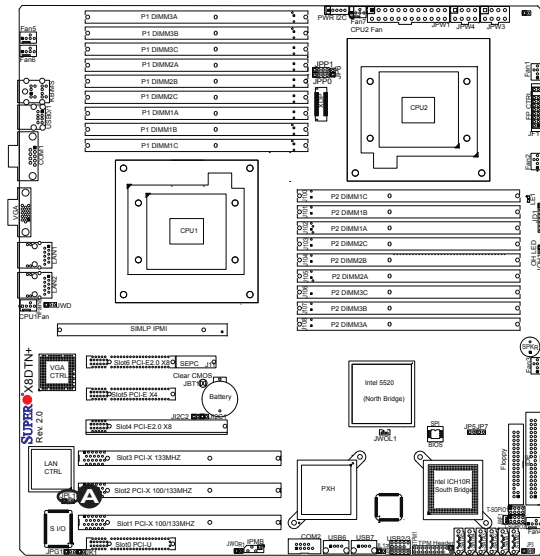

A. GLAN Ports 1/2 Enable

CMOS Clear

JBT1 is used to clear CMOS. Instead of pins, this "jumper" consists of contact pads to prevent the accidental clearing of CMOS. To clear CMOS, use a metal object such as a small screwdriver to touch both pads at the same time to short the connection. Always remove the AC power cord from the system before clearing CMOS.

 **Note:** For an ATX power supply, you must completely shut down the system, remove the AC power cord and then short JBT1 to clear CMOS.



Watch Dog Enable/Disable

Watch Dog (JWD) is a system monitor that can reboot the system when a software application hangs. Close Pins 1-2 to reset the system if an application hangs. Close Pins 2-3 to generate a non-maskable interrupt signal for the application that hangs. See the table on the right for jumper settings. Watch Dog must also be enabled in the BIOS.

Watch Dog Jumper Settings	
Jumper Setting	Definition
Pins 1-2	Reset (default)
Pins 2-3	NMI
Open	Disabled

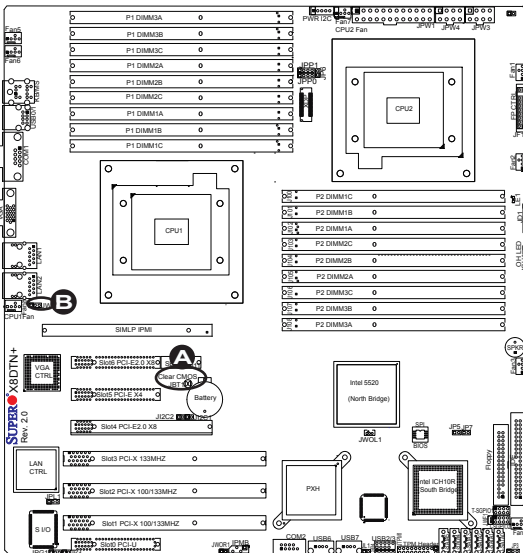

- A. Clear CMOS
- B. Watch Dog Enable

I²C Bus to PCI-X/PCI-E Slots

Jumpers J1²C1 and J1²C2 allow you to connect the System Management Bus (I²C) to PCI-X/PCI-E slots. The default setting is Open to disable the connection. See the table on the right for jumper settings.

I ² C to PCI-Exp/PCI-X slots Jumper Settings	
Jumper Setting	Definition
Closed	Enabled
Open	Disabled (Default)

VGA Enable/Disable

JPG1 allows you to enable the on-board VGA connection. The default position is on pins 1 and 2 to use this feature. See the table on the right for jumper settings.

VGA Enable Jumper Settings	
Jumper Setting	Definition
1-2	VGA Enabled (Default)
2-3	VGA Disabled

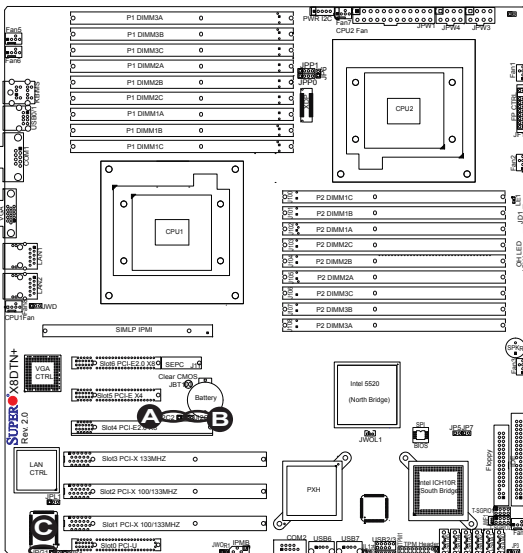

- A. J12 (J1²C1)
- B. J13 (J1²C2)
- C. VGA Enable

IDE Enable/Disable

Jumper JP3 allows you to enable or disable the onboard IDE connector. The default setting is Pins 1-2 to enable the connection. See the table on the right for jumper settings.

IDE Enable Jumper Settings	
Jumper	Definition
1-2	IDE Enable (Default)
2-3	IDE Disable

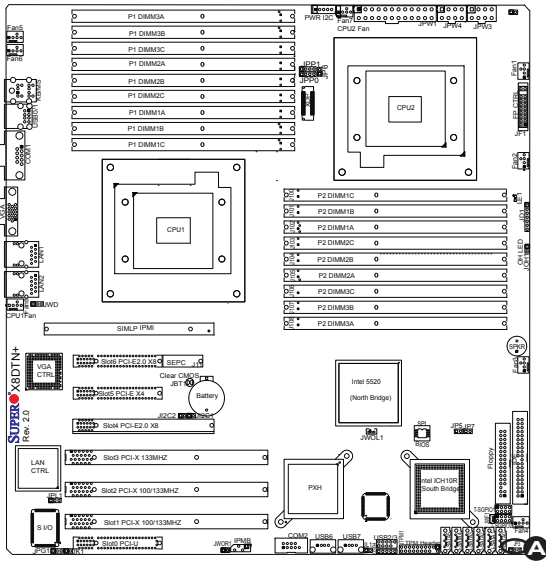

A. IDE Enable

2-8 Onboard Indicators

GLAN LEDs

There are two GLAN ports on the motherboard. Each Gigabit Ethernet LAN port has two LEDs. The yellow LED indicates activity, while the Link LED may be green, amber or off to indicate the speed of the connection. See the tables at right for more information.

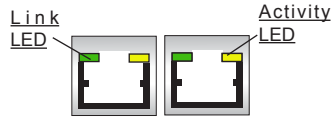

Rear View (when facing the rear side of the chassis)

GLAN Activity (Right) Indicator LED Settings		
Color	Status	Definition
Yellow	Flashing	Active

GLAN Link (Left) Indicator LED Settings	
LED Color	Definition
Off	No Connection or 10 Mbps
Green	100 Mbps
Amber	1 Gbps

Onboard Power LED

An Onboard Power LED is located at LE1 on the motherboard. When this LED is lit, the system is on. Be sure to turn off the system and unplug the power cord before removing or installing components. See the tables at right for more information.

Onboard PWR LED Indicator (LE1)	
LED Color	Definition
Off	System Off (PWR cable not connected)
Green	System On
Green: Flashing	ACPI S1 State

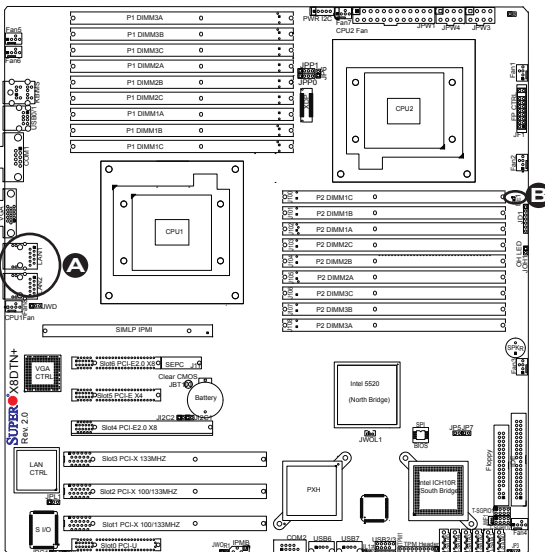

A. GLAN Port LEDs

B. Onboard Power LED

2-9 Floppy Drive, SIMLP, Serial ATA and HDD Connections

Note the following when connecting the floppy and hard disk drive cables:

- The SATA disk drive cable has seven twisted wires.
- A red mark on a wire typically designates the location of pin 1.
- A single floppy disk drive ribbon cable has 34 wires and two connectors to provide for two floppy disk drives. The connector with twisted wires always connects to drive A, and the connector that does not have twisted wires always connects to drive B.

Floppy Connector

The floppy connector is located next to the IDE slot on the motherboard. See the table on the right for pin definitions.

Floppy Drive Connector Pin Definitions			
Pin#	Definition	Pin #	Definition
1	Ground	2	FDHDIN
3	Ground	4	Reserved
5	Key	6	FDEDIN
7	Ground	8	Index
9	Ground	10	Motor Enable
11	Ground	12	Drive Select B
13	Ground	14	Drive Select B
15	Ground	16	Motor Enable
17	Ground	18	DIR
19	Ground	20	STEP
21	Ground	22	Write Data
23	Ground	24	Write Gate
25	Ground	26	Track 00
27	Ground	28	Write Protect
29	Ground	30	Read Data
31	Ground	32	Side 1 Select
33	Ground	34	Diskette

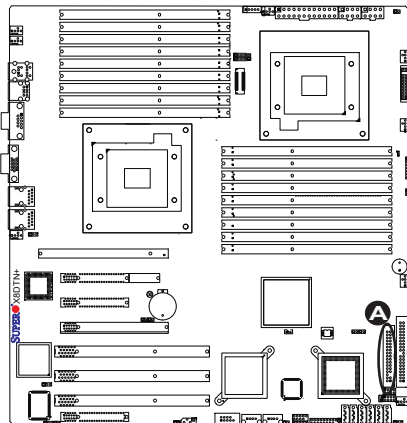

A. Floppy

Serial ATA Ports

Six Serial ATA Ports (I-SATA0~I-SATA 5) are located at JS1~JS6 on the motherboard. These ports provide serial-link signal transmission, which is faster than that of the traditional Parallel ATA. See the table on the right for pin definitions.

Serial ATA Pin Definitions	
Pin#	Definition
1	Ground
2	TX_P
3	TX_N
4	Ground
5	RX_N
6	RX_P
7	Ground

SIMLP IPMI Slot

The SIMLP IPMI (Supermicro Intelligent Management) Slot is located at next to CPU2 on the motherboard. Refer to the layout below for the SIMLP IPMI Slot location.

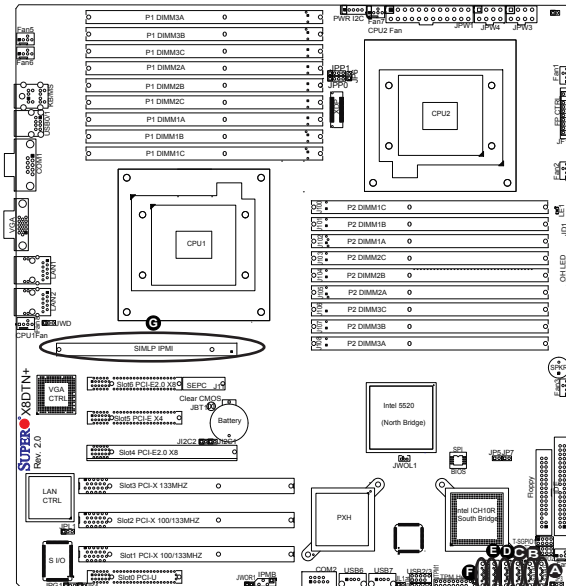

- A. I-SATA0
- B. I-SATA1
- C. I-SATA2
- D. I-SATA3
- E. I-SATA4
- F. I-SATA5
- G. SIMLP

IDE Connector

An IDE Connector is located at JIDE1 on the motherboard. This connector provides HDD IO connection. This slot can also be used for a compact flash card. For use with a compact flash card, please connect a power cable to the compact flash power connector located at JWF1 to provide power to the compact flash device installed on the slot. See the table on the right for pin definitions.

IDE Drive Connector Pin Definitions			
Pin#	Definition	Pin #	Definition
1	Reset IDE	2	Ground
3	Host Data 7	4	Host Data 8
5	Host Data 6	6	Host Data 9
7	Host Data 5	8	Host Data 10
9	Host Data 4	10	Host Data 11
11	Host Data 3	12	Host Data 12
13	Host Data 2	14	Host Data 13
15	Host Data 1	16	Host Data 14
17	Host Data 0	18	Host Data 15
19	Ground	20	Key
21	DRQ3	22	Ground
23	I/O Write	24	Ground
25	I/O Read	26	Ground
27	IOCHRDY	28	BALE
29	DACK3	30	Ground
31	IRQ14	32	IOCS16
33	Addr1	34	Ground
35	Addr0	36	Addr2
37	Chip Select 0	38	Chip Select 1
39	Activity	40	Ground

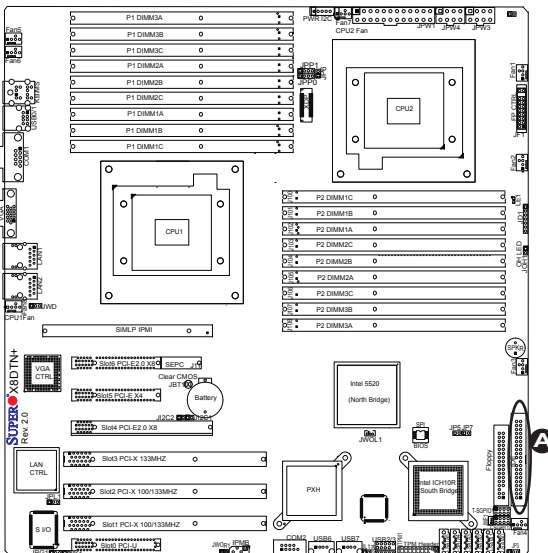

A. IDE slot

Chapter 3

Troubleshooting

3-1 Troubleshooting Procedures

Use the following procedures to troubleshoot your system. If you have followed all of the procedures below and still need assistance, refer to the 'Technical Support Procedures' and/or 'Returning Merchandise for Service' section(s) in this chapter. Note: Always disconnect the power cord before adding, changing or installing any hardware components.

Before Power On

1. Make sure that there are no short circuits between the motherboard and chassis.
2. Disconnect all ribbon/wire cables from the motherboard, including those for the keyboard and mouse.
3. Remove all add-on cards.
4. Install CPU 1 first (-making sure it is fully seated) and connect the chassis speaker and the power LED to the motherboard. (Check all jumper settings as well.)

No Power

1. Make sure that no short circuits between the motherboard and the chassis.
2. Make sure that all jumpers are set to their default positions.
3. Check that the 115V/230V switch on the power supply is properly set.
4. Turn the power switch on and off to test the system.
5. The battery on your motherboard may be old. Check to verify that it still supplies ~3VDC. If it does not, replace it with a new one.

No Video

1. If the power is on but you have no video, remove all the add-on cards and cables.
2. Use the speaker to determine if any beep codes exist. Refer to the Appendix for details on beep codes.

Losing the System's Setup Configuration

1. Make sure that you are using a high quality power supply. A poor quality power supply may cause the system to lose the CMOS setup information. Refer to Section 1-6 for details on recommended power supplies.
2. The battery on your motherboard may be old. Check to verify that it still supplies ~3VDC. If it does not, replace it with a new one.
3. If the above steps do not fix the Setup Configuration problem, contact your vendor for repairs.

Memory Errors

When a No_Memory_Beep_Code is issued by the system, check the following:

1. Make sure that the DIMM modules are properly and fully installed.
2. Check if different speeds of DIMMs have been installed. It is strongly recommended to use the same RAM speed for all DIMMs in the system.
3. Make sure you are using the correct type of DDR3 Registered/Load Reduced/Unbuffered SDRAM modules as recommended by the manufacturer. Refer to Page 1-6 in Chapter 1 for memory support.
4. Check for bad DIMM modules or slots by swapping a single module between all memory slots and check the results.
5. Make sure that all memory modules are fully seated in their slots. Make sure to follow the instructions given in Section 2-4 in Chapter 2.
6. Check the position of the 115V/230V switch on the power supply.
7. Please follow the instructions given in the DIMM Population Tables listed on Page 2-8 to install your memory modules.

3-2 Technical Support Procedures

Before contacting Technical Support, please take the following steps. Also, please note that as a motherboard manufacturer, Supermicro does not sell directly to end-users, so it is best to first check with your distributor or reseller for troubleshooting services. They should know of any possible problem(s) with the specific system configuration that was sold to you.

1. Please go through the 'Troubleshooting Procedures' and 'Frequently Asked Question' (FAQ) sections in this chapter or see the FAQs on our web site (<http://www.supermicro.com/support/faqs/>) before contacting Technical Support.
2. BIOS upgrades can be downloaded from our web site at (<http://www.supermicro.com/support/bios/>).
3. If you still cannot resolve the problem, include the following information when contacting Supermicro for technical support:
 - Motherboard model and PCB revision number
 - BIOS release date/version (this can be seen on the initial display when your system first boots up)
 - System configuration
 - An example of a Technical Support form is on our web site at (<http://www.supermicro.com/support/contact.cfm>).
 - Distributors: For immediate assistance, please have your account number ready when placing a call to our technical support department. We can be reached by e-mail at support@supermicro.com or by fax at: (408) 503-8000, option 2.

3-3 Frequently Asked Questions

Question: What are the various types of memory that my motherboard can support?

Answer: The X8DTN+/X8DTN+-LR has 18 240-pin DIMM slots that support DDR3 Registered/Load Reduced/Unbuffered SDRAM modules. Refer to Page 1-6 in Chapter 1 for memory support. It is strongly recommended that you do not mix memory modules of different speeds and sizes. Please follow all memory installation instructions in Section 2-4 in Chapter 2.

Question: How do I update my BIOS?

It is recommended that you **do not** upgrade your BIOS if you are not experiencing any problems with your system. Updated BIOS files are located on our web site at <http://www.supermicro.com/support/bios/>. Please check our BIOS warning message and the information on how to update your BIOS on our web site. Select your motherboard model and download the BIOS file to your computer. Also, check the current BIOS revision and make sure that it is newer than your BIOS before downloading. You can choose from the zip file and the .exe file. If you choose the zip BIOS file, please unzip the BIOS file onto a bootable USB device. Run the batch file using the format flash.bat filename.rom from your bootable USB device to flash the BIOS. Then, your system will automatically reboot.



Warning: Do not shut down or reset the system while updating the BIOS to prevent possible system boot failure!)



Note: The SPI BIOS chip used on this motherboard cannot be removed. Send your motherboard back to our RMA Department at Supermicro for repair. For BIOS Recovery instructions, please refer to the AMI BIOS Recovery Instructions posted at <http://www.supermicro.com/support/manuals/>.

Question: What's on the CD that came with my motherboard?

Answer: The supplied compact disc has quite a few drivers and programs that will greatly enhance your system. We recommend that you review the CD and install the applications you need. Applications on the CD include chipset drivers for the Windows OS, security and audio drivers.

Question: How do I handle the used battery?

Answer: Please handle used batteries carefully. Do not damage the battery in any way; a damaged battery may release hazardous materials into the environment. Do not discard a used battery in the garbage or a public landfill. Please comply with the regulations set up by your local hazardous waste management agency to dispose of your used battery properly.

3-4 Returning Merchandise for Service

A receipt or copy of your invoice marked with the date of purchase is required before any warranty service will be rendered. You can obtain service by calling your vendor for a Returned Merchandise Authorization (RMA) number. When returning to the manufacturer, the RMA number should be prominently displayed on the outside of the shipping carton, and mailed prepaid or hand-carried. Shipping and handling charges will be applied for all orders that must be mailed when service is complete.

For faster service, You can also request a RMA authorization online (<http://www.supermicro.com/support/rma/>).

This warranty only covers normal consumer use and does not cover damages incurred in shipping or from failure due to the alternation, misuse, abuse or improper maintenance of products.

During the warranty period, contact your distributor first for any product problems.

Notes

Chapter 4

BIOS

4-1 Introduction

This chapter describes the AMI BIOS Setup Utility for the X8DTN+/X8DTN+-LR. The AMI ROM BIOS is stored in a Flash EEPROM and can be easily updated. This chapter describes the basic navigation of the AMI BIOS Setup Utility setup screens.

Starting BIOS Setup Utility

To enter the AMI BIOS Setup Utility screens, press the <Delete> key while the system is booting up.



Warning: For your system memory to work properly, be sure to use the correct BIOS ROM for your system. For the X8DTN+ use the X8DTN+ BIOS. For the X8DTN+-LR, use the X8DTN+-LR BIOS. Refer to memory support in Section 2-4 of Chapter 2 for more details.



Note: In most cases, the <Delete> key is used to invoke the AMI BIOS setup screen. There are a few cases when other keys are used, such as <F1>, <F2>, etc.

Each main BIOS menu option is described in this manual. The Main BIOS setup menu screen has two main frames. The left frame displays all the options that can be configured. Grayed-out options cannot be configured. Options in blue can be configured by the user. The right frame displays the key legend. Above the key legend is an area reserved for a text message. When an option is selected in the left frame, it is highlighted in white. Often a text message will accompany it. (**Note:** the AMI BIOS has default text messages built in. Supermicro retains the option to include, omit, or change any of these text messages.)

The AMI BIOS Setup Utility uses a key-based navigation system called "hot keys". Most of the AMI BIOS setup utility "hot keys" can be used at any time during the setup navigation process. These keys include <F1>, <F10>, <Enter>, <ESC>, arrow keys, etc.



Note: Options printed in **Bold** are default settings.

How To Change the Configuration Data

The configuration data that determines the system parameters may be changed by entering the AMI BIOS Setup utility. This Setup utility can be accessed by pressing at the appropriate time during system boot.

 **Note:** For AMI BIOS Recovery, please refer to the AMI BIOS Recovery Instructions posted on our website at <http://www.supermicro.com/support/manuals/>.

Starting the Setup Utility

Normally, the only visible Power-On Self-Test (POST) routine is the memory test. As the memory is being tested, press the <Delete> key to enter the main menu of the AMI BIOS Setup Utility. From the main menu, you can access the other setup screens. An AMI BIOS identification string is displayed at the left bottom corner of the screen below the copyright message.

 **Warning!** Do not upgrade the BIOS unless your system has a BIOS-related issue. Flashing the wrong BIOS can cause irreparable damage to the system. In no event shall Supermicro be liable for direct, indirect, special, incidental, or consequential damages arising from a BIOS update. If you have to update the BIOS, do not shut down or reset the system while the BIOS is updating. This is to avoid possible boot failure.

4-2 Main Setup

When you first enter the AMI BIOS Setup Utility, you will enter the Main setup screen. You can always return to the Main setup screen by selecting the Main tab on the top of the screen. The Main BIOS Setup screen is shown below.

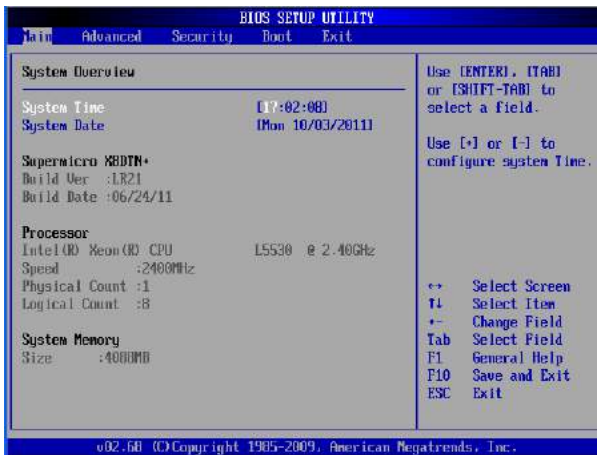

System Overview: The following BIOS information will be displayed:

System Time/System Date

Use this option to change the system time and date. Highlight *System Time* or *System Date* using the arrow keys. Enter new values through the keyboard and press <Enter>. Press the <Tab> key to move between fields. The date must be entered in MM/DD/YY format. The time is entered in HH:MM:SS format. (**Note:** The time is in the 24-hour format. For example, 5:30 P.M. appears as 17:30:00.)

Supermicro X8DTN+

- **BIOS Build Version:** This item displays the BIOS revision used in your system.
- **BIOS Build Date:** This item displays the date when this BIOS was built.

Processor

The AMI BIOS will automatically display the status of the processor used in your system:

- **CPU Type:** This item displays the type of processor used in the motherboard.
- **Speed:** This item displays the speed of the processor detected by the BIOS.
- **Physical Count:** This item displays the number of processors installed in your system as detected by the BIOS.
- **Logical Count:** This item displays the number of CPU Cores installed in your system as detected by the BIOS.

System Memory

This displays the size of memory available in the system:

- **Size:** This item displays the memory size detected by the BIOS.

4-3 Advanced Setup Configurations

Use the arrow keys to select Boot Setup and press <Enter> to access the submenu items.

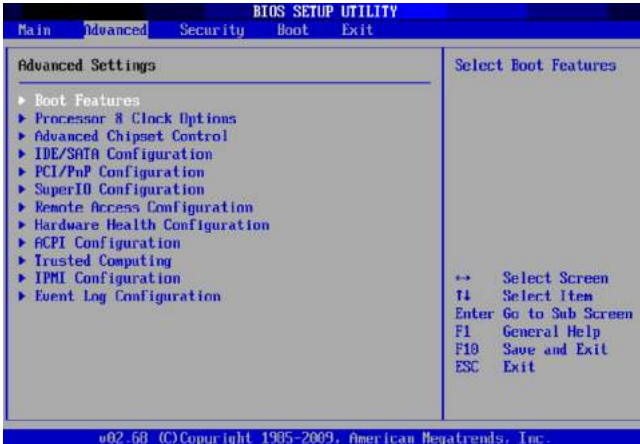

► Boot Features

Quick Boot

If Enabled, this option will skip certain tests during POST to reduce the time needed for system boot. The options are **Enabled** and Disabled.

Quiet Boot

This option allows the user to modify the bootup screen display between POST messages and the OEM logo. Select Disabled to display the POST messages. Select Enabled to display the OEM logo instead of the normal POST messages. The options are **Enabled** and Disabled.

AddOn ROM Display Mode

This sets the display mode for the Option ROM. The options are **Force BIOS** and Keep Current.

Bootup Num-Lock

This feature selects the Power-on state for Numlock key. The options are Off and **On**.

Wait For 'F1' If Error

This feature forces the system to wait until the 'F1' key is pressed if an error occurs. The options are Disabled and **Enabled**.

Hit 'Del' Message Display

This feature displays "Press DEL to run Setup" during POST. The options are **Enabled** and Disabled.

Interrupt 19 Capture

Interrupt 19 is the software interrupt that handles the boot disk function. When this item is set to Enabled, the ROM BIOS of the host adaptors will "capture" Interrupt 19 at boot and allow the drives that are attached to these host adaptors to function as bootable disks. If this item is set to Disabled, the ROM BIOS of the host adaptors will not capture Interrupt 19, and the drives attached to these adaptors will not function as bootable devices. The options are **Enabled** and Disabled.

Power Configuration

Power Button Function

If this feature is set to Instant_Off, the system will power off immediately as soon as the user presses the power button. If this feature is set to 4_Second_Override, the system will power off when the user presses the power button for 4 seconds or longer. The options are **Instant_Off** and 4_Second_Override.

Restore on AC Power Loss

Use this feature to set the power state after a power outage. Select Power-Off for the system power to remain off after a power loss. Select Power-On for the system power to be turned on after a power loss. Select Last State to allow the system to resume its last state before a power loss. The options are Power-On, Power-Off and **Last State**.

Watch Dog Timer

If enabled, the Watch Dog Timer will allow the system to reboot when it is inactive for more than 5 minutes. The options are Enabled and **Disabled**.

► Processor and Clock Options

This submenu allows the user to configure the Processor and Clock settings.

CPU Ratio

This option allows the user to set the ratio between the CPU Core Clock and the FSB Frequency. (**Note:** if an invalid ratio is entered, the AMI BIOS will restore the setting to the previous state.) The default setting is Auto which will allow the BIOS set the ratio depending on the CPU installed on the board. The default setting is **Auto**.

Ratio CMOS Setting

This feature displays the ratio between the CPU Core Clock and the FSB Frequency. The default setting depends on the type of CPU installed on the motherboard. The default setting for the CPU installed in your motherboard is **[18]**.

C1E Support

Select Enabled to enable Enhanced Halt State support which will significantly lower CPU's power consumption by reducing the CPU's clock cycle and voltage during a "Halt State." The options are Disabled and **Enabled**.

Hardware Prefetcher (Available when supported by the CPU)

If this feature is set to Enabled, the hardware prefetcher will prefetch streams of data and instructions from the main memory to the L2 cache to improve CPU performance. The options are Disabled and **Enabled**.

Adjacent Cache Line Prefetch (Available when supported by the CPU)

The CPU prefetches the cache line for 64 bytes if this option is set to Disabled. The CPU prefetches both cache lines for 128 bytes as comprised if **Enabled**.

DCU Prefetcher (Available when supported by the CPU)

Select Enabled to activate Level 1 Data Prefetcher to enhance system performance. For DP servers, enable or disable this feature based on application specifications. The options are **Enabled** and Disabled.

Data Reuse Optimization (Available when supported by the CPU)

Select Enabled to maximize Data Reuse support to enhance system performance for DP platforms. For DP servers, enable or disable this feature based on application specifications. The options are **Enabled** and Disabled.

MPS and ACPI MADT Ordering

This feature allows the user to configure the MPS (Multi-Processor Specification) and ACPI settings for your motherboard. Select **Modern Ordering** if the XP or a newer version of Windows OS is used in the motherboard. Select Legacy Ordering if the 2000 or an earlier version of Windows OS is used. The options are **Modern Ordering** and Legacy Ordering.

Intel® Virtualization Technology (Available when supported by the CPU)

Select Enabled to use the feature of Virtualization Technology and allow one platform to run multiple operating systems and applications in independent partitions, creating multiple "virtual" systems in one physical computer. The options are **Enabled** and Disabled. **Note:** If there is any change to this setting, you will need to power off and restart the system for the change to take effect. Please refer to Intel's web site for detailed information.

Execute-Disable Bit Capability (Available when supported by the OS and the CPU)

Select **Enabled** to enable the Execute Disable Bit which will allow the processor to designate areas in the system memory where an application code can execute and where it cannot, thus preventing a worm or a virus from flooding illegal codes to overwhelm the processor or damage the system during an attack. The default is **Enabled**. (Refer to Intel and Microsoft Web Sites for more information.)

Intel AES-NI (Available when supported by the OS and the CPU)

If this feature is set to **Enabled**, Intel AES-NI will add new encryption features to help accelerate AES Software application, providing code authorization and signature verification to improve system performance. The default is **Disabled**. (Refer to Intel and Microsoft Web Sites for more information.)

Simultaneous Multi-Threading (Available when supported by the CPU)

Set to **Enabled** to use the Simultaneous Multi-Threading Technology, which will result in increased CPU performance. The options are **Disabled** and **Enabled**.

Active Processor Cores

Set to **Enabled** to use a processor's Second Core and beyond. (Please refer to Intel's web site for more information.) The options are **All**, 1 and 2.

Intel® EIST Technology

EIST (Enhanced Intel SpeedStep Technology) allows the system to automatically adjust processor voltage and core frequency in an effort to reduce power consumption and heat dissipation. **Please refer to Intel's web site for detailed information.** The options are **Disable** (Disable GV3) and **Enable (Enable GV3)**.

Intel® Turbo Boost (Available when Intel® EIST Technology is enabled)

Select **Enabled** to use the Turbo Mode to boost system performance. The options are **Enabled** and **Disabled**.

Performance/Watt Select

Select **Power Optimized** to use the Turbo Boost mode after the system has been in the P0 state for more than 2 seconds. Select **Traditional** to use the Turbo Boost mode when the system has been in the P0 state less than 2 seconds. The options are **Power Optimized** and **Traditional**.

Intel® C-STATE Tech

If enabled, C-State is set by the system automatically to either C2, C3 or C4 state. The options are **Disabled** and **Enabled**.

C3 State

This feature allows the user to decide how the onboard 5500/5600 Series processor will act at C3 State. The options are Disabled, **ACPI 2** and **ACPI 3**.

C6 State

This feature allows the user to decide how the onboard 5500/5600 Series processor will act at C6 State. The options are Disabled and **Enabled**.

C7 State

This feature allows the user to decide how the onboard 5500/5600 Series processor will act at C7 State which is a processor-specific, low power C-State. The options are Disabled and **Enabled**.

C-State package limit setting (Available when Intel® C-State Tech is enabled)

If set to Auto, the AMI BIOS will automatically set the limit on the C-State package register. The options are **Auto**, C1, C3, C6 and C7.

C1 Auto Demotion

When this feature is enabled, the CPU will conditionally demote C3, C6 or C7 requests to C1 based on un-core auto-demote information. The options are Disabled and **Enabled**.

C3 Auto Demotion

When this feature is enabled, the CPU will conditionally demote C6 or C7 requests to C3 based on un-core auto-demote information. The options are Disabled and **Enabled**.

ACPI T State

When this feature is enabled, CPU Throttling state will be reported in the ACPI (Advanced Configuration and Power Interface) protocol. The options are Disabled and **Enabled**.

Clock Spread Spectrum

Select Enable to use the feature of Clock Spread Spectrum, which will allow the BIOS to monitor and attempt to reduce the level of Electromagnetic Interference caused by the components whenever needed. The options are **Disabled** and **Enabled**.

►Advanced Chipset Control

The items included in the Advanced Settings submenu are listed below:

► CPU Bridge Configuration

QPI (Quick Path Interconnect) Links Speed

This feature selects data transfer speed for QPI Link connections. The options are Slow-Mode, and **Full Speed**.

QPI Frequency (Available if the item - QPI Speed is set to Full Speed)

This feature allows the user to select the desired QPI frequency. The options are **Auto**, 4.800 GT, 5.866GT, 6.400 GT.

QPI L0s and L1

This feature allows the user to set the QPI power state to a low setting. L0s and L1 are automatically selected by the motherboard. The options are **Disabled** and Enabled.

Memory Frequency

This feature forces a DDR3 module to run at a frequency other than what is specified in the specification. Select Force SPD (Serial Presence Detect) to force the module to run at a frequency specified on the SPD table. The available options are **Auto**, Force DDR-800, Force DDR-1066, Force DDR-1333 and Force SPD.

Memory Mode

The options are **Independent**, Channel Mirroring, and Lockstep.

When this feature is set to Independent, all DIMMs are available to the operating system.

When this feature is set to Channel Mirroring, the motherboard will maintain two identical copies of all data in memory for redundancy.

When this feature is set to Lockstep, the motherboard will use two areas of memory to run the same set of operations in parallel.

Demand Scrubbing

Demand Scrubbing is a memory error-correction scheme that allows the processor to write corrected data back into the memory block from where it was read by the Processor. The options are Enabled and **Disabled**.

Patrol Scrubbing

Select Enabled to use Patrol Scrubbing, a memory error-correction scheme that works in the background to look for and correct errors. The options are **Enabled** and Disabled.

Throttling - Closed Loop/Throttling - Closed Loop

Throttling improves reliability and reduces power in the processor by automatic voltage control during processor idle states. The options are Disabled and **Enabled**. If Enabled, the following items will appear:

Hysteresis Temperature (Available for Closed Loop only)

Temperature Hysteresis is the temperature lag (in degrees Celsius) after the set DIMM temperature threshold is reached before Closed Loop Throttling begins. The options are Disabled, **1.5°C**, 3.0°C, and 6.0°C.

Guardband Temperature (Available for Closed Loop only)

This is the temperature which applies to the DIMM temperature threshold. Each step is in 0.5°C increment. The default is **[006]**.

Inlet Temperature

This is the temperature detected at the chassis inlet. Each step is in 0.5°C increment. The default is **[070]**.

Temperature Rise

This is the temperature rise to the DIMM thermal zone. Each step is in 0.5°C increment. The default is **[020]**.

Air Flow

This is the air flow speed to the DIMM modules. Each step is one mm/sec. The default is **[1500]**.

Altitude

This feature defines how many meters above or below sea level the system is located. The options are **Sea Level or Below**, 1~300, 301~600, 601~900, 901~1200, 1201~1500, 1501~1800, 1801~2100, 2101~2400, 2401~2700, 2701~3000.

DIMM Pitch

This is the physical space between each DIMM module. Each step is in 1/1000 of an inch. The default is **[400]**.

► North Bridge Configuration

This feature allows the user to configure the settings for the Intel North Bridge.

Intel I/O AT

This feature works in conjunction with the Intel I/O AT (Acceleration Technology) to accelerate the performance of TOE devices. (**Note:** A TOE device is a special-

ized, dedicated processor that is installed on an add-on card or a network card to handle some or all packet processing of this add-on card.) When this feature is set to Enabled, it will enhance overall system performance by providing direct memory access for data transferring. The options are **Enabled** and Disabled.

DCA (Direct Cache Access) Technology (Available when Intel I/O AT is enabled)

This feature works in conjunction with the Intel I/O AT (Acceleration Technology) to accelerate the performance of the TOE device. When this feature set to Enabled, it will enhance overall system performance by providing direct cache access for data transferring. The options are **Enabled** and Disabled.

DCA Prefetch Delay

A DCA Prefetch is used with TOE components to prefetch data in order to shorten execution cycles and maximize data processing efficiency. Prefetching too frequently can saturate the cache directory and delay necessary cache accesses. This feature reduces or increases the frequency the system prefetches data. The options are [8], [16], [24], [**32**], [40], [48], [56], [64], [72], [80], [88], [96], [104], [112], [120]

Intel VT-d

Select Enabled to enable Intel's Virtualization Technology support for Direct I/O VT-d by reporting the I/O device assignments to VMM through the DMAR ACPI Tables. This feature offers fully-protected I/O resource-sharing across the Intel platforms, providing the user with greater reliability, security and availability in networking and data-sharing. The settings are **Enabled** and Disabled.

Active State Power-Management

Select enable to configure the power states of PCI-Express L0s and L1 links. The options are Enabled and **Disabled**.

IOH PCIE Max Payload Size

Some add-on cards perform faster with the coalesce feature, which limits the payload size to 128B; while others, with a payload size of 256B which inhibits the coalesce feature. Please refer to your add-on card user guide for the desired setting. The options are **256B** and 128MB.

► South Bridge Configuration

This feature allows the user to configure the settings for the Intel South Bridge.

USB Functions

Select Enabled to use the onboard USB ports. The Options are: Disabled, and **Enabled**. (If this item is set to Enabled, USB 2.0 Controller will be enabled.)

Legacy USB Support

Select Enabled to use Legacy USB devices. If this item is set to Auto, Legacy USB support will be automatically enabled if a legacy USB device is installed on the motherboard, and vice versa. The settings are Disabled, **Enabled** and Auto.

USB 2.0 Controller

Select Enabled to activate USB 2.0 Controller. The options are **Enabled** and Disabled. (**Note:** If the item - USB Functions is enabled, USB 2.0 Controller will always be enabled. When the item - USB Functions is set to Disabled, the user has the option to enable or disable USB 2.0 Controller.)

USB 2.0 Controller Mode

This setting allows you to select the USB 2.0 Controller mode. The options are **Hi-Speed (480 Mbps)** and Full Speed (12 Mbps).

BIOS EHCI Hand-Off

Select Enabled to enable BIOS Enhanced Host Controller Interface support to provide a workaround solution for an operating system that does not have EHCI Hand-Off support. When enabled, the EHCI Interface will be changed from the BIOS-controlled to the OS-controlled. The options are Disabled and **Enabled**.

►ME Subsystem Configuration

This feature allows the user to configure ME Subsystem Configuration settings.

ME-EHCI

Select Enabled to enable Intel ME EHCI (Management Engine Enhanced Host Controller Interface) support. The options are **Enabled** and Disabled.

►Intel PCI-X Hub Configuration

PCI Bus A0/B0 Frequency

This option allows the user to set the maximum PCI speed to be used in the PCI slot specified. Select Auto to allow the BIOS to automatically detect the capability of the device installed on the bus. The options are **Auto**, 33 MHz PCI, 66 MHz PCI, 66 MHz PCI-X M1, 100 MHz PCI-X M1, and 133 MHz PCI-X M1.

I/O Port Decode

This option allows the user to select the decode range for the I/O connections. The options are **4K Decode** and 1K Decode.

RAS Sticky Error Handling

This option allows the user to decide how to handle Sticky RAS errors. The options are **Clear Errors** and Leave Errors (unchanged).

VGA 16-Bit Decode

Select Enabled to enable the function of decoding VGA for the devices installed behind the PXH PCI Controller Hub. The options are **Enabled** and Disabled.

► IDE/SATA Configuration

When this submenu is selected, the AMI BIOS automatically detects the presence of the IDE devices and displays the following items.

SATA#1 Configuration

If Compatible is selected, it sets SATA#1 to legacy compatibility mode, while selecting Enhanced sets SATA#1 to native SATA mode. The options are Disabled, Compatible and **Enhanced**.

Configure SATA#1 as

This feature allows the user to select the drive type for SATA#1. The options are **IDE**, RAID and AHCI. (When the option-RAID is selected, the item-ICH RAID Code Base will appear.)

ICH RAID Code Base (This feature is available when the option-RAID is selected)

Select Intel to enable Intel's SATA RAID firmware to configure Intel's SATA RAID settings. Select Adaptec to enable Adaptec's SATA RAID firmware to configure Adaptec's SATA RAID settings. The options are **Intel** and Adaptec.

SATA#2 Configuration (This feature is available when the option-IDE is selected)

Selecting Enhanced will set SATA#2 to native SATA mode. The options are Disabled, and **Enhanced**.

Primary IDE Master/Slave, Secondary IDE Master/Slave, Third IDE Master, and Fourth IDE Master

Use these items to set the parameters of Primary IDE Master/Slave, Secondary IDE Master/Slave, Third and Fourth IDE Master slots. Press <Enter> to activate the following sub-items. Set the correct configurations accordingly.

Type

Select the type of device connected to the system. The options are Not Installed, **Auto**, CD/DVD and ARMD.

LBA/Large Mode

LBA (Logical Block Addressing) is a method of addressing data on a disk drive. In the LBA mode, the maximum drive capacity is 137 GB. For drive capacities over 137 GB, your system must be equipped with a 48-bit LBA mode addressing. If not, contact your manufacturer or install an ATA/133 IDE controller card that supports 48-bit LBA mode. The options are Disabled and **Auto**.

Block (Multi-Sector Transfer)

Block Mode boosts the IDE drive performance by increasing the amount of data transferred. Only 512 bytes of data can be transferred per interrupt if Block Mode is not used. Block Mode allows transfers of up to 64 KB per interrupt. Select Disabled to allow data to be transferred from and to the device one sector at a time. Select Auto to allow data transfer from and to the device occur multiple sectors at a time if the device supports it. The options are **Auto** and Disabled.

PIO Mode

The IDE PIO (Programmable I/O) Mode programs timing cycles between the IDE drive and the programmable IDE controller. As the PIO mode increases, the cycle time decreases. The options are **Auto**, 0, 1, 2, 3, and 4.

Select Auto to allow the AMI BIOS to automatically detect the PIO mode. Use this value if the IDE disk drive support cannot be determined.

Select 0 ~ 4 to allow the AMI BIOS to use PIO mode 0 ~ 4. It has a data transfer rate of 3.3 MB/s ~ 16.6 MB/s. See the table below.

PIO Mode Select Options

Option Selected	PIO Mode	Max. Transfer Rate
0	PIO Mode 0	3.3 MB/s
1	PIO Mode 1	5.2 MB/s
2	PIO Mode 2	8.3 MB/s
3	PIO Mode 3	11.1 MB/s
4	PIO Mode 4	16.6 MB/s

DMA Mode

Select Auto to allow the BIOS to automatically detect IDE DMA mode when the IDE disk drive support cannot be determined. The options are **Auto**, SWDMAN, MWDMAN, and UDMAN. See the table below for DMA Mode Select Options.

DMA Mode Select Options

Option Selected	DMA Mode	Max. Transfer Rate
SWDMA 0	Single-Word DMA 0	2.1 MB/s
SWDMA1	Single-Word DMA 1	4.2 MB/s
SWDMA 2	Single-Word DMA 2	8.3MB/s
MWDMA 0	Multi-Word DMA 0	4.2 MB/s

MWDMA1	Multi-Word DMA 1	13.3 MB/s
MWDMA 2	Multi-Word DMA 2	16.6 MB/s
UDMA 0	Ultra DMA 0	16.6 MB/s
UDMA 1	Ultra DMA 1	25 MB/s
UDMA 2	Ultra DMA 2	33.3 MB/s
UDMA 3	Ultra DMA 3	44.4 MB/s
UDMA 4	Ultra DMA 4	66.6 MB/s
UDMA5	Ultra DMA 5	100 MB/s
UDMA 6	Ultra DMA 6	133 MB/s

S.M.A.R.T. For Hard disk drives

Self-Monitoring Analysis and Reporting Technology (SMART) can help predict impending drive failures. Select Auto to allow the AMI BIOS to automatically detect hard disk drive support. Select Disabled to prevent the AMI BIOS from using the S.M.A.R.T. Select Enabled to allow the AMI BIOS to use the S.M.A.R.T. to support hard drive disk. The options are Disabled, Enabled, and **Auto**.

32Bit Data Transfer

Select Enable to enable the function of 32-bit IDE data transfer. The options are **Enabled** and Disabled.

IDE Detect Timeout (sec)

Use this feature to set the timeout value for the BIOS to detect the ATA, ATAPI devices installed in the system. The options are 0 (sec), 5, 10, 15, 20, 25, 30, and **35**.

► PCI/PnP Configuration

Clear NVRAM

This feature clears the NVRAM (Non-Volatile Random Access Memory) during system boot. The options are **No** and Yes.

Plug & Play OS

Selecting Yes allows the OS to configure Plug & Play devices. (This is not required for system boot if Plug & Play is supported by your OS.) Select **No** to allow the AMI BIOS to configure all devices in the system.

PCI Latency Timer

This feature sets the latency Timer of each PCI device installed on a PCI bus. Select 64 to set the PCI latency to 64 PCI clock cycles. The options are 32, **64**, 96, 128, 160, 192, 224 and 248.

PCI IDE BusMaster

When this item is enabled, the BIOS uses PCI bus mastering for reading/writing to IDE drives. The options are Disabled and **Enabled**.

SR-IOV Supported

Select Enabled to enable SR-IOV (Intel Single Root I/O Virtualization) support to enhance Virtualization performance. The options are Enabled and **Disabled**.

Slot1~Slot3 PCI-X Option ROM/Slot4~Slot6 PCI-E Option ROM

Select Enabled to enable the onboard PCI Slot Option ROM as specified (except the VGA card). This is to boot computer using a network interface. The options are **Enabled** and Disabled.

Load Onboard LAN1 Option ROM/Load Onboard LAN2 Option ROM

Select Enabled to enable the onboard LAN1 or LAN2 Option ROM. This is to boot computer using a network interface. The options are Enabled and **Disabled**.

Onboard LAN Option ROM Select

This feature allows the user to select the onboard LAN option ROM type. The options are iSCSI and **PXE**.

Boot Graphics Adapter Priority

This feature allows the user to select the priority graphics adapter for system boot. The options are Onboard VGA and **Offboard VGA**.

► Super IO Device Configuration

Onboard Floppy Controller

Select Enabled to enable the onboard floppy controller. The options are Disabled and **Enabled**.

Serial Port1 Address/ Serial Port2 Address

This option specifies the base I/O port address and the Interrupt Request address of Serial Port 1 and Serial Port 2. Select Disabled to prevent the serial port from accessing any system resources. When this option is set to Disabled, the serial port physically becomes unavailable. Select 3F8/IRQ4 to allow the serial port to use 3F8 as its I/O port address and IRQ 4 for the interrupt address. The options for Serial Port1 are Disabled, **3F8/IRQ4**, 3E8/IRQ4, 2E8/IRQ3. The options for Serial Port2 are Disabled, **2F8/IRQ3**, 3E8/IRQ4, and 2E8/IRQ3.

Serial Port 2 Attribute

Use this feature to set COM 2 as a normal serial port or a virtual COM port for **SOL** (Serial Over LAN). The options are **SOL** and **COM**.

Floppy A

This feature allows the user to select the type of floppy drive connected to the system as specified. The options are Disabled, 360KB 5 1/4", 1.2MB 5 1/4", 720KB 3 1/2", **1.44MB 3 1/2"** and 2.88MB 3 1/2".

► Remote Access Configuration

Remote Access

Use this item to enable or disable Remote Access support. The options are **Disabled** and **Enabled**. If Remote Access is set to Enabled, the following items will display:

Serial Port Number

This feature allows the user decide which serial port to be used for Console Redirection. The options are COM 1 and **COM 2**.

Base Address, IRQ

This item displays the based address and IRQ of the serial port specified above. The default setting is **2F8h, 3**.

Serial Port Mode

This feature allows the user to set the serial port mode for Console Redirection. The options are **115200 8, n 1**; 57600 8, n, 1; 38400 8, n, 1; 19200 8, n, 1; and 9600 8, n, 1.

Flow Control

This feature allows the user to set the flow control for Console Redirection. The options are **None**, Hardware, and Software.

Redirection After BIOS POST

Select Disabled to turn off Console Redirection after Power-On Self-Test (POST). Select Always to keep Console Redirection active all the time after POST. (**Note:** This setting may not be supported by some operating systems.) Select Boot Loader to keep Console Redirection active during POST and Boot Loader. The options are Disabled, Boot Loader, and **Always**.

Terminal Type

This feature allows the user to select the target terminal type for Console Redirection. The options are **ANSI**, VT100, and VT-UTF8.

VT-UTF8 Combo Key Support

This is a terminal keyboard that can send commands from a remote console. The options are **Enabled** and Disabled.

Sredir Memory Display Delay

This feature defines the length of time in seconds to display memory information. The options are **No Delay**, Delay 1 Sec, Delay 2 Sec, and Delay 4 Sec.

►Hardware Health Configuration

This feature allows the user to monitor system health and review the status of each item as displayed.

CPU Overheat Alarm

This option allows the user to select the CPU Overheat Alarm setting which determines when the CPU OH alarm will be activated to provide warning of possible CPU overheat.



Warning! 1.Any temperature that exceeds the CPU threshold temperature predefined by the CPU manufacturer may result in CPU overheat or system instability. When the CPU temperature reaches this predefined threshold, the CPU and system cooling fans will run at full speed. 2. To avoid possible system overheating, please be sure to provide adequate airflow to your system.

The options are:

- **The Early Alarm:** Select this setting if you want the CPU overheat alarm (including the LED and the buzzer) to be triggered as soon as the CPU temperature reaches the CPU overheat threshold as predefined by the CPU manufacturer.
- **The Default Alarm:** Select this setting if you want the CPU overheat alarm (including the LED and the buzzer) to be triggered when the CPU temperature reaches about 5°C above the threshold temperature as predefined by the CPU manufacturer to give the CPU and system fans additional time needed for CPU and system cooling. In both the alarms above, please take immediate action as shown below.

CPU Temperature 2/CPU Temperature 1/System Temperature

This feature displays current temperature readings for the CPU and the System.

The following items will be displayed for your reference only:

CPU 1 Temperature/CPU 2 Temperature

The CPU thermal technology that reports absolute temperatures (Celsius/Fahrenheit) has been upgraded to a more advanced feature by Intel in its newer processors. The basic concept is each CPU is embedded by unique temperature information that the motherboard can read. This 'Temperature Threshold' or 'Temperature Tolerance' has been assigned at the factory and is the baseline on which the motherboard takes action during different CPU temperature conditions (i.e., by increasing CPU Fan speed, triggering the Overheat Alarm, etc). Since CPUs can have different 'Temperature Tolerances', the installed CPU can now send information to the motherboard what its 'Temperature Tolerance' is, and not the other way around. This results in better CPU thermal management.

Supermicro has leveraged this feature by assigning a temperature status to certain thermal conditions in the processor (Low, Medium and High). This makes it easier for the user to understand the CPU's temperature status, rather than by just simply seeing a temperature reading (i.e., 25°C). The CPU Temperature feature will display the CPU temperature status as detected by the BIOS:

Low – This level is considered as the 'normal' operating state. The CPU temperature is well below the CPU 'Temperature Tolerance'. The motherboard fans and CPU will run normally as configured in the BIOS (Fan Speed Control).

Medium – The processor is running warmer. This is a 'precautionary' level and generally means that there may be factors contributing to this condition, but the CPU is still within its normal operating state and below the CPU 'Temperature Tolerance'. The motherboard fans and CPU will run normally as configured in the BIOS. The fans may adjust to a faster speed depending on the Fan Speed Control settings.

User intervention: No action is required. However, consider checking the CPU fans and the chassis ventilation for blockage.

High – The processor is running hot. This is a 'caution' level since the CPU's 'Temperature Tolerance' has been reached (or has been exceeded) and may activate an overheat alarm.

User intervention: If the system buzzer and Overheat LED has activated, take action immediately by checking the system fans, chassis ventilation and room temperature to correct any problems.



Notes: 1. The system may shut down if it continues for a long period to prevent damage to the CPU.

2. The information provided above is for your reference only. For more information on thermal management, please refer to Intel's Web site at www.Intel.com.

System Temperature: The system temperature will be displayed (in degrees in Celsius and Fahrenheit) as it is detected by the BIOS.

Fan Speed Readings

This feature displays the fan speed readings from Fan1 through Fan8.

Fan Speed Control Modes

This feature allows the user to decide how the system controls the speeds of the onboard fans. The CPU temperature and the fan speed are correlative. When the CPU on-die temperature increases, the fan speed will also increase for effective system cooling. Select "Full Speed/FS" to allow the onboard fans to run at full speed for maximum cooling. The FS setting is recommended for special system configuration or debugging. Select "Performance/PF" for better system cooling. The PF setting is recommended for high-power-consuming and high-density systems. Select "Balanced/BL" for the onboard fans to run at a speed that will balance the needs between system cooling and power saving. The BL setting is recommended for regular systems with normal hardware configurations. Select "Energy Saving/ES" for best power efficiency and maximum quietness. The Options are: Full Speed/**FS**, Performance/**PF**, **Balanced/BL**, and Energy Saving/**ES**.

Voltages Readings

The following voltage readings will be displayed.

CPU1 Vcore, CPU2 Vcore, +5Vin, +5Vsb, +12V, CPU1 DIMM, CPU2 DIMM, 3.3Vcc, 3.3Vsb, and Battery Voltage

►ACPI Configuration

Use this feature to configure Advanced Configuration and Power Interface (ACPI) power management settings for your system.

ACPI Aware O/S (Available when supported by the OS)

If this feature is supported by the OS, select Enabled for the OS to control ACPI. Otherwise, disable this feature. The options are **Yes** and **No**.

ACPI Version Features

The options are ACPI v1.0, **ACPI v2.0** and ACPI v3.0. Please refer to ACPI's website for further explanation: <http://www.acpi.info/>.

ACPI APIC Support

Select Enabled to include the ACPI APIC Table Pointer in the RSDT (Root System Description Table) pointer list. The options are **Enabled** and **Disabled**.

APIC ACPI SCI IRQ

When this item is set to Enabled, APIC ACPI SCI IRQ is supported by the system. The options are Enabled and **Disabled**.

Headless Mode

Select Enabled for the system to function normally without a keyboard, monitor or mouse attached. The options are Enabled and **Disabled**.

NUMA Support

Select Enabled to use Non-Uniform Memory Access to improve CPU performance. The options are Disabled, **Enabled** and NUMA for SLES 11.

ACPI SLIT Table

Select Enabled to enable ACPI SLIT (System Locality Information Table) support to indicate the distances between all processors, memory controllers and host bridges. The options are **Enabled** and Disabled.

High Performance Event Timer

Select Enabled to activate the High Performance Event Timer (HPET) that produces periodic interrupts at a much higher frequency than a Real-time Clock (RTC) does in synchronizing multimedia streams, providing smooth playback and reducing the dependency on other timestamp calculation devices, such as an x86 RDTSC Instruction embedded in the CPU. The High Performance Event Timer is used to replace the 8254 Programmable Interval Timer. The options are **Enabled** and Disabled.

WHEA Support

Select Enabled to enable Windows Hardware Error Architecture (WHEA) support which will provide a common infrastructure for handling hardware errors on Windows platforms in order to reduce system crashes due to hardware errors and improve system recovery and health monitoring. The default setting is **Enabled**.

► Trusted Computing (Available when a TPM device is installed on the motherboard)

TCG/TPM Support

Select Yes on this item and enable the TPM jumper on the motherboard to enable TCG (TPM 1.1/1.2)/TPM support in order to improve data integrity and network security. The options are **No** and Yes. If this feature is set to Yes, the following items will display.

Execute TPM Command

Select Enabled to execute TPM commands you've selected. Select Don't Change to keep the current TPM commands without making any changes. Select Disabled to abandon the changes you have made on TPM commands. The options are Enabled, Disabled and **Don't Change**.

TPM Enable/Disable Status

This item displays the status of TPM Support to indicate if TPM is currently enabled or disabled.

TPM Owner Status

This item displays the status of TPM Ownership.

►Event Log Configuration

View Event Log

Use this option to view the System Event Log.

Mark all Events as Read

This option marks all events as read. The options are **OK** and Cancel.

Clear Event Log

This option clears the Event Log memory of all messages. The options are **OK** and Cancel.

PCI-E Error Log

Select Yes to use the PCI-E error log. The options are Yes and **No**.

4-4 Security Settings

The AMIBIOS Setup Utility provides a Supervisor and a User password. If you use both passwords, the Supervisor password must be set first.

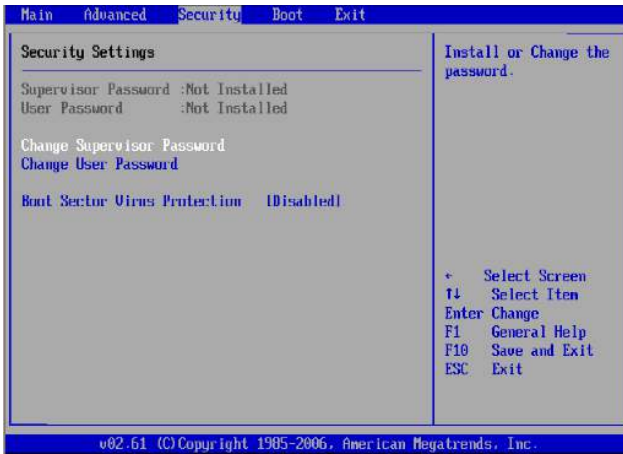

Supervisor Password

This feature indicates if a supervisor's password has been entered (installed).

User Password

This feature indicates if a user's password has been entered (installed).

Change Supervisor Password

Select this item, press <Enter> to enter a supervisor password.

Change User Password

Select this item, press <Enter> to access the submenu and enter a user password.

Clear User Password (Available only if User Password has been set)

This item allows you to clear a user password after it has been entered.

Password Check

Select Setup for the system to check for a password at Setup. Select Always for the system to check for a password at bootup. The options are **Setup** and Always.

Boot Sector Virus Protection

When this item is enabled, the AMI BIOS displays a warning when any program (or virus) issues a Disk Format command or attempts to write to the boot sector of the hard disk drive. The options are Enabled and **Disabled**.

4-5 Boot Configuration

Use this feature to configure boot settings.

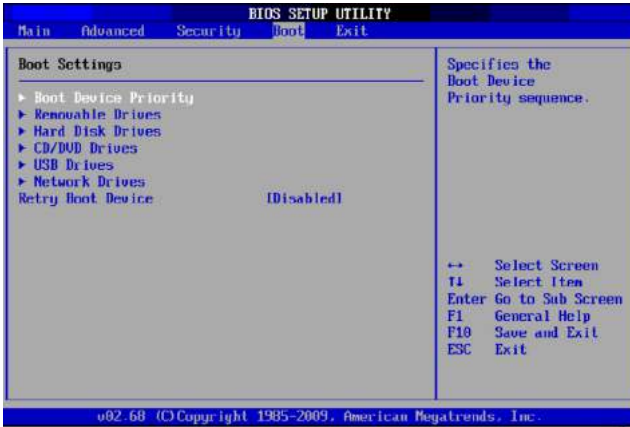

► Boot Device Priority

This feature allows the user to specify the sequence of priority for the Boot Device. The settings are available boot devices and Disabled.

- 1st Boot Device/2nd Boot Device/3rd Boot Drive/4th Boot Drive/5th Boot Drive

► Removable Drives

This feature allows the user to specify the boot sequence from available Removable Drives. The settings are 1st boot device, 2nd boot device, and Disabled.

- 1st Drive - [1st Floppy Drive]

► Hard Disk Drives

This feature allows the user to specify the boot sequence from all available hard disk drives. The settings are Disabled and a list of all HDDs detected.

- 1st Drive

► CD/DVD Drives

This feature allows the user to specify the boot sequence from all available CD/DVD drives. The settings are Disabled, and a list of CD/DVD devices as detected.

- 1st Drive

► USB Drives

This feature allows the user to specify the boot sequence from all available USB devices. The settings are Disabled, and a list of CD/DVD devices as detected.

- 1st Drive

► Network Drives

This feature allows the user to specify the boot sequence from all available network drives. The settings are Disabled, and a list of network devices as detected.

- 1st Drive

Retry Boot Devices

Select Enabled to enable Retry Boot Devices support to allow the system to attempt to boot from a specific boot device after a boot failure. The options are Enabled and **Disabled**.

4-6 Exit Options

Select the Exit tab from the AMI BIOS Setup Utility screen to enter the Exit BIOS Setup screen.



Save Changes and Exit

When you have completed the system configuration changes, select this option to leave the BIOS Setup Utility and reboot the computer so that the new system configuration parameters can take effect. Select Save Changes and Exit from the Exit menu and press <Enter>.

Discard Changes and Exit

Select this option to quit the BIOS Setup without making any permanent changes to the system configuration, and reboot the computer. Select Discard Changes and Exit from the Exit menu and press <Enter>.

Discard Changes

Select this option and press <Enter> to discard all the changes and return to the AMI BIOS Utility Program.

Load Optimal Defaults

Select this feature, press <Enter>, and select OK to allow the AMI BIOS to automatically load Optimal Defaults to the BIOS Settings. The Optimal settings are designed for maximum system performance, but may not work best for all computer applications.

Load Fail-Safe Defaults

Select this feature, and press <Enter> to load Fail-Safe default settings. These settings are designed for maximum system stability, but not for maximum performance.

Appendix A

BIOS Error Beep Codes

During the POST (Power-On Self-Test) routines, which are performed each time the system is powered on, errors may occur.

Non-fatal errors are those which, in most cases, allow the system to continue the boot-up process. The error messages normally appear on the screen.

Fatal errors are those which will not allow the system to continue the boot-up procedure. If a fatal error occurs, you should consult with your system manufacturer for possible repairs.

These fatal errors are usually communicated through a series of audible beeps. The numbers on the fatal error list correspond to the number of beeps for the corresponding error.

A-1 BIOS Error Beep Codes

BIOS Error Beep Codes		
Beep Code	Error Message	Description
1 beep	Refresh	Circuits have been reset. (Ready to power up)
5 short beeps + 1 long beep	Memory error	No memory detected in the system
8 beeps	Display memory read/write error	Video adapter missing or with faulty memory
1 continuous beep w/ Front Panel OH LED on	System Overheat	1 continuous beep with the front panel OH LED on

Notes

Appendix B

Software Installation Instructions

B-1 Installing Software Programs

After you've installed the Windows Operating System, a screen as shown below will appear. You are ready to install software programs and drivers that have not yet been installed. To install these software programs and drivers, click the icons to the right of these items. (To install the Windows OS, please refer to the Windows OS Installation Guide posted at <http://www.supermicro.com/support/manuals/>.)

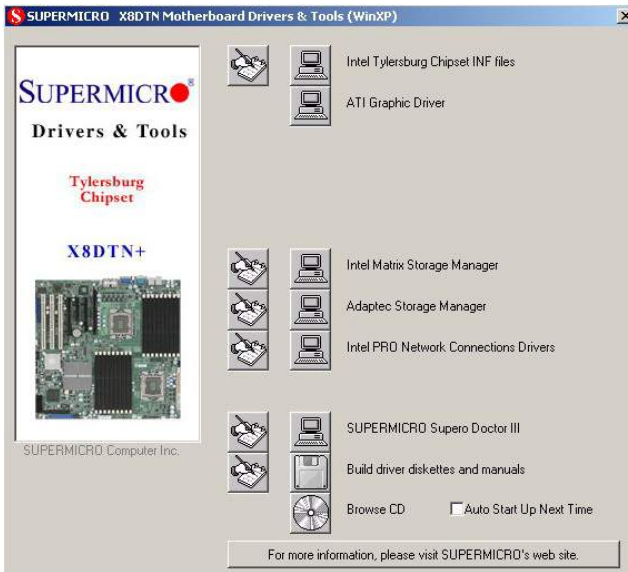

Driver/Tool Installation Display Screen



Note 1. Click the icons showing a hand writing on the paper to view the readme files for each item. Click on a computer icon to the right of an item to install an item (from top to the bottom) one at a time. After installing each item, you must re-boot the system before proceeding with the next item on the list. The bottom icon with a CD on it allows you to view the entire contents of the CD.

Note 2. When making a storage driver diskette from booting into a Driver CD, please set the SATA Configuration to "Compatible Mode" and configure SATA as IDE in the BIOS Setup. After making the driver diskette, be sure to change the SATA settings back to your original settings.

B-2 Configuring Supero Doctor III Settings

The Supero Doctor III program is a Web-based management tool that supports remote management capability. It includes Remote and Local Management tools. The local management is called the SD III Client. The Supero Doctor III program included on the CDROM that came with your motherboard allows you to monitor the environment and operations of your system. Supero Doctor III displays crucial system information such as CPU temperature, system voltages and fan status. See the Figure below for a display of the Supero Doctor III interface.



Note: 1 The default user name and password are ADMIN.

Note 2: In the Windows OS environment, the Supero Doctor III settings take precedence over the BIOS settings. When first installed, Supero Doctor III adopts the temperature threshold settings previously set in BIOS. Any subsequent changes to these thresholds must be made within Supero Doctor, since the SD III settings override the BIOS settings. For the Windows OS to adopt the BIOS temperature threshold settings, please change the SDIII settings to be the same as those set in BIOS.

Supero Doctor III Interface Display Screen-I (Health Information)



Supero Doctor III Interface Display Screen-II (Remote Control)



Note: SD III Software Revision 1.0 can be downloaded from our Web site at: ftp://ftp.supermicro.com/utility/Supero_Doctor_III/. You can also download SDIII User's Guide at: <http://www.supermicro.com/PRODUCT/Manuals/SDIII/UserGuide.pdf>. For Linux, we will still recommend that you use Supero Doctor II.

Notes

(Disclaimer Continued)

The products sold by Supermicro are not intended for and will not be used in life support systems, medical equipment, nuclear facilities or systems, aircraft, aircraft devices, aircraft/emergency communication devices or other critical systems whose failure to perform be reasonably expected to result in significant injury or loss of life or catastrophic property damage. Accordingly, Supermicro disclaims any and all liability, and should buyer use or sell such products for use in such ultra-hazardous applications, it does so entirely at its own risk. Furthermore, buyer agrees to fully indemnify, defend and hold Supermicro harmless for and against any and all claims, demands, actions, litigation, and proceedings of any kind arising out of or related to such ultra-hazardous use or sale.